

# Quartz Movements

## Classic Functions

### RONDA slimtech

CALIBER 1063 – 6¾ x 8'''

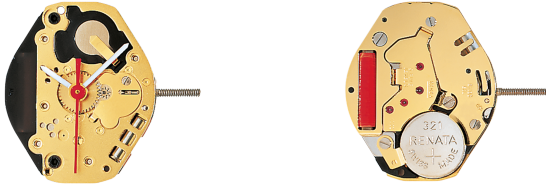

## Product Specifications

Analog quartz movement

Line	slimtech
Caliber	1063
Size	6¾ x 8'''
Version Swiss Made	5 Jewels / gold plated EOL
Version Swiss Parts	1 Jewels / nickel plated
Standard battery life	25 months
High battery life	34 months
Standard hand fitting height	1

## Functions

- 3 hands

## Features

- Repairable metal watch movement
- Power saving mechanism with pulled out stem:  
Reduction of consumption approximately 70%
- Complete interchangeability between 1062-1064

## CALIBER 1063 – 6¾ x 8'''

### Technical Specifications

Diameter Total	15.30 mm
Case fitting	15.30 mm
Movement height	1.90 mm
Height over standard battery	1.95 mm
Height over high battery	2.55 mm
Movement rest	0.40 mm
Height over stem	0.75 mm
Length of stem travel	0.35 mm
Stem thread	0.90 mm
Useful torque second – typical	5 µNm
Useful torque minute – typical	250 µNm
Operating temperature	0 - 50 °C
Instantaneous rate	-10/ +20 sec/month
Resistance to magnetic fields	18.8 Oe
Resistance against shock	NIHS 91-10

### Battery Specifications

Standard battery	No. 321
High battery	No. 364
Standard battery life	25 months
High battery life	34 months
Battery voltage	1.5 V
Current consumption – typical	0.82 µA
Current consumption – maximum	1.15 µA

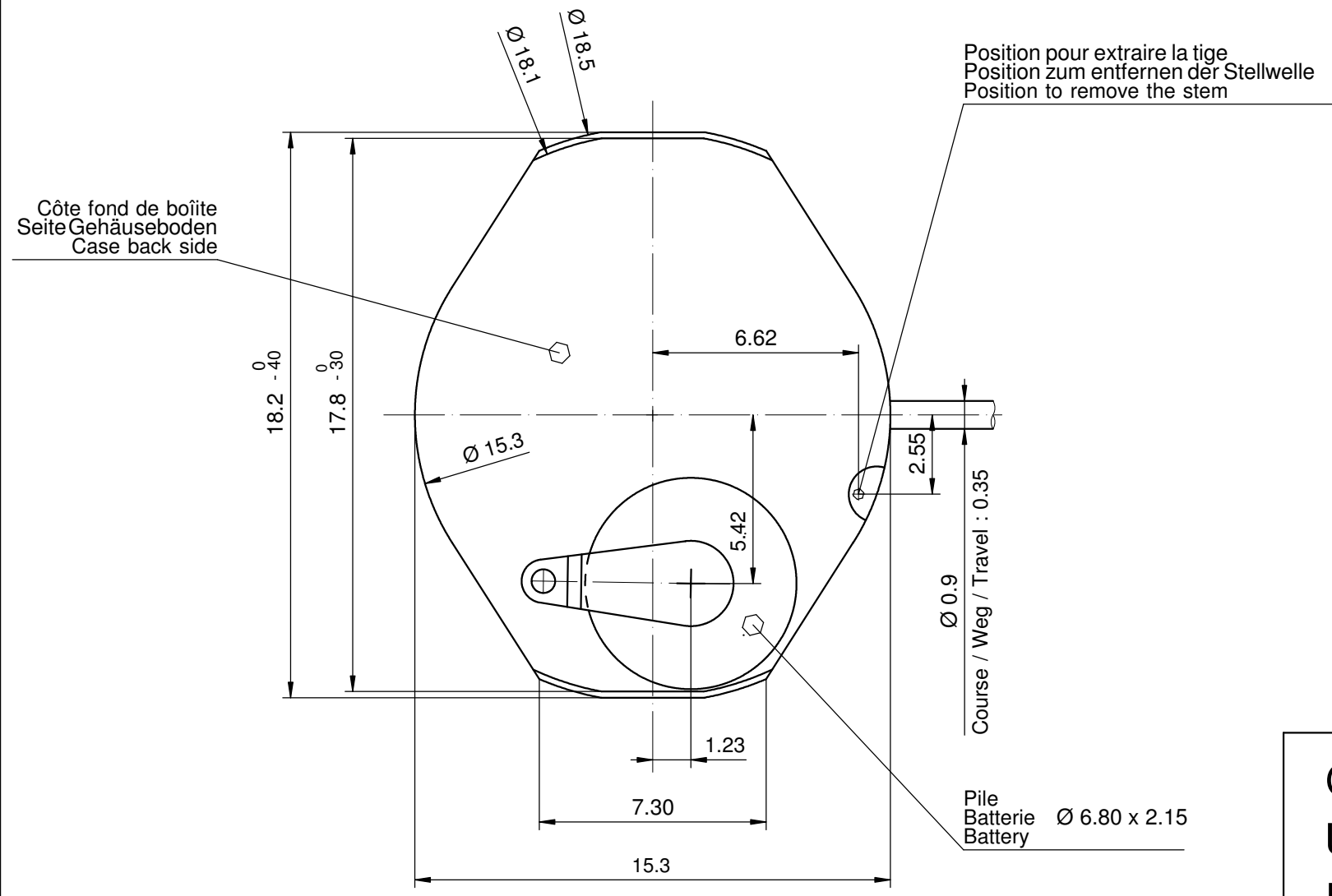
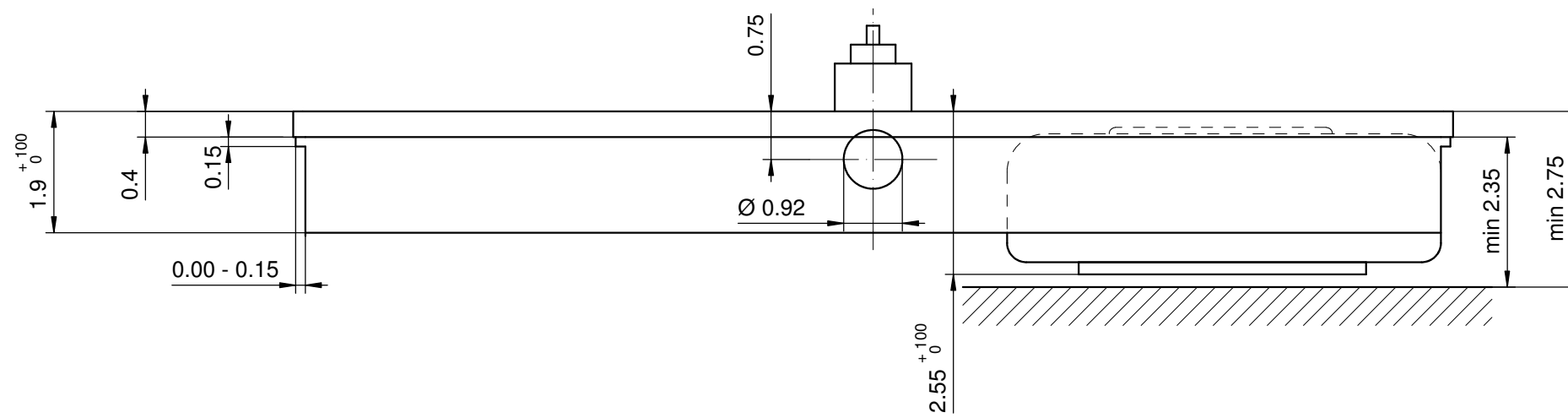

Sécurité entre aiguille minute et verre : min 0.30 mm  
 Sicherheit zwischen Minutenzeiger und Glas : min 0.30 mm  
 Security between minute hand and glass : min 0.30 mm

Le cadran doit être maintenu en hauteur par la boîte.  
 Das Zifferblatt muss in der Höhe vom Gehäuse festgehalten werden.  
 The dial must be held in the height by the case.

<b>Cage</b> <b>Uhrwerkgestell 6¾ x 8'''</b> <b>Frame</b>		Issued	12 Feb 2013	dh
		Modified	01 Okt 2013 ÄA 13220	dh
		Released	YES	
		Tolerance	+/- 20 µm	
		Scale	10 : 1 (5 : 1) (A3H)	
<b>RONDA</b>	<b>1062, 1063</b>	Pile Batterie Battery Ø6.80 x 2.15	Sous réserve de modifications Aenderungenvorbehalten Modifications reserved	
			No.	5000.402

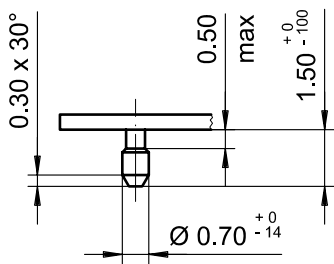
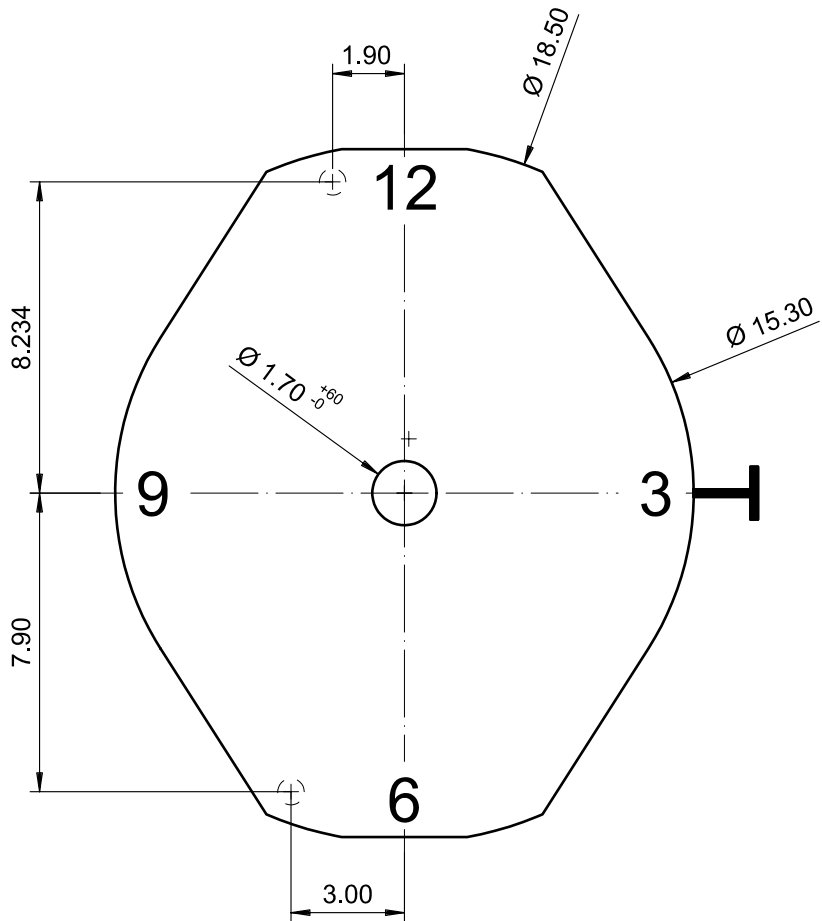

Epaisseur du cadran selon hauteur de l'aiguillage  
 Zifferblattdicke gemäss Zeigerwerkhöhen  
 Dial thickness according to hand fitting heights

Tige
Stellw.
Stem
<b>3H</b>

Cadran Zifferblatt Dial	$6\frac{3}{4} \times 8'''$	Issued	13 Dez 2006	cw
		Modified	15.Dez.2006 ÄA ----	cm
		Released	YES	
		Tolerance	+/- 20 µm	
		Scale	5 : 1 (A4V)	
RONDA	1062, 1063	Sous réserve de modifications Aenderungen vorbehalten Modifications reserved		
		No.	5010.478	03

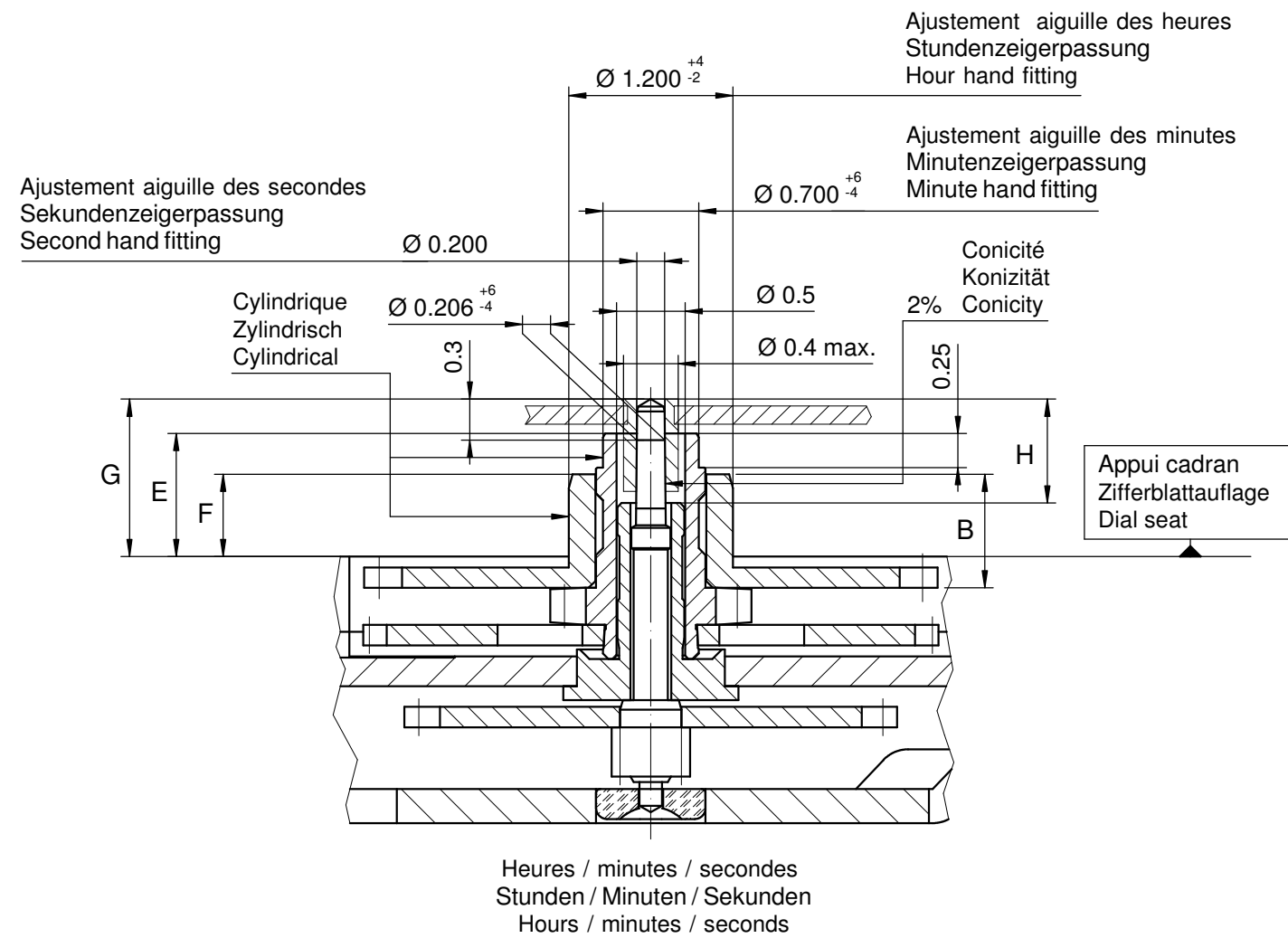

Aiguillage no Zeigerwerkhöhe Nr. Hand fitting height No	Dépassement Höhe über Zifferblattauflage Height over dial seat			Longueur Länge Length		Epaisseur max. (peinture comprise) Max. Dicke (inkl. Farbe) Max. thickness (paint included)			
	Pignon des secondes Sekundentrieb Second pinion	Chaussée Minutenrohr Cannon-pinion	Roue des heures Stundenrad Hour wheel	H	B	Cadran Zifferblatt Dial			Aiguilles Zeiger Hands
						Sous l'aiguille des secondes Unter Sekundenzeiger Under second hand	Sous l'aiguille des minutes Unter Minutenzeiger Under minute hand	Sous l'aiguille des heures Unter Stundenzeiger Under hour hand	
	G	E	F	H	B				
0	1.15	0.90	0.60	0.76	0.83	0.65	0.50	0.30	0.15
1	1.40	1.10	0.80	1.01	1.03	0.90	0.70	0.40	0.15
2	1.55	1.25	0.95	1.16	1.18	1.05	0.85	0.60	0.15

	Aig. des secondes Sekundenzeiger Second hand	Aig. des minutes Minutenzeiger Minute hand	Aig. des heures Stundenzeiger Hour hand	Lors de la pose d'aiguilles, le mouvement doit être soutenu. Beim Zeigersetzen muss das Werk abgestützt werden. The movement needs to be supported for hand setting.
mg max.	10	30	30	Masse / Masse / Weight *
µNm max.	0.04	0.60	0.60	Balourd / Unwucht / Unbalance *
gmm <sup>2</sup> max.	0.2	-	-	Inertie / Massenträgheit / Inertia *
N max.	30	40	40	Force de chassage / Aufpresskraft / Force

Sous réserve de toutes modifications

Aenderungen vorbehalten

All modifications reserved

Aiguillages  
Zeigerwerkhöhen  
Hand fitting heights

6<sup>3</sup>/<sub>4</sub> x 8'''

RONDA

1063

Issued	21 Feb 1996	os
Modified	18 Feb 2011 ÅA 10340	ps
Released	Yes	
Tolerance	µm	
Scale	20 : 1 (A3H)	
Sous réserve de modifications Aenderungen vorbehalten Modifications reserved		
No.	3316.052	06

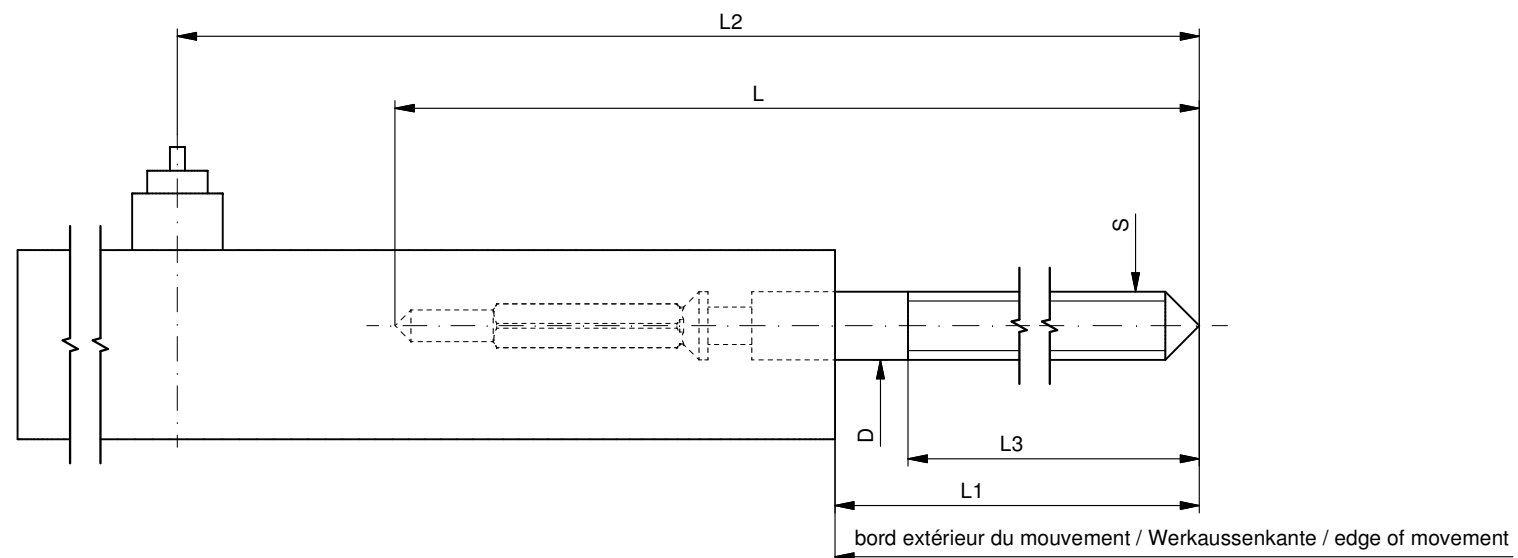

Tige de travail (intégrée dans le mouvement)  
 Arbeitstellwelle (im Werk eingebaut)  
 Working stem (implemented in the movement)

No. d'article Artikelnummer Part number	L	L1	L2	L3	S	D
3000.160.CO	16.00	11.65	19.30	11.41	0.90	0.80

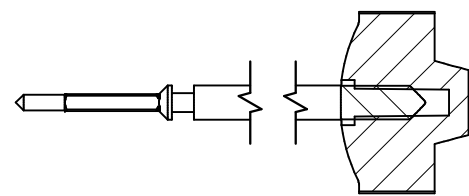

Couleur de la couronne Kronenfarbe Crown color	vert foncé dunkelgrün dark green
Code	UN 6020

Tige (normale) / Stellwelle (normal) / Stem (normal)

No. d'article Artikelnummer Part number	L	L1	L2	L3	S	D
3000.160	16.00	11.65	19.30	11.41	0.90	0.80
3000.165	20.00	15.65	23.30	11.46	0.90	0.80

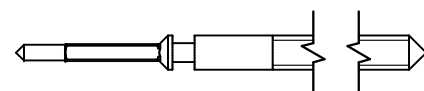

Couronne normale  
 Normale Krone  
 Normal crown

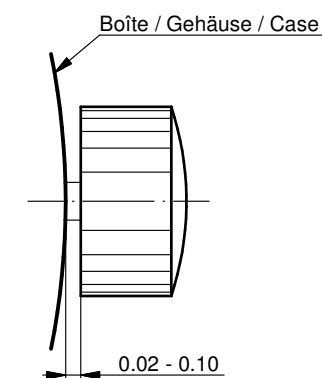

Couronne vissée  
 Geschraubte Krone  
 Screwed crown

Force ⇐ min. Kraft ⇐ min. Force ⇐ min.	10 N
Force ⇐ max. Kraft ⇐ max. Force ⇐ max.	15 N

Rallonge de tige / Stellwelle Verlängerung / Stem extension

No. d'article Artikelnummer Part number	L4	L5 (min)	L6	S1	S2	D1
3000.040	12.00	1.90	2.60	0.90	0.90	1.35

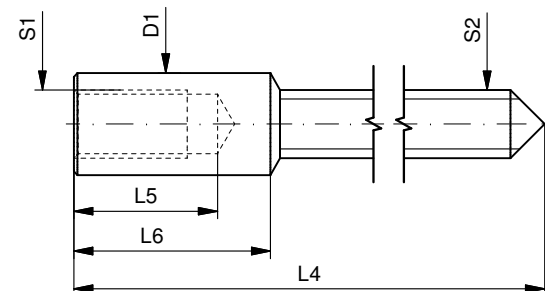

Tige (dimensions / forces)  
 Stellwelle (Dimensionen / Kräfte)  
 Stem (dimensions / forces)

RONDA 1062, 1063, 1064, 1069

Issued	03 Sep 2012	ds5222
Modified	17 Mär 2017 ÄA 34582	mg5224
Released	YES	
Tolerance	---	
Scale	10:1 (A3)	

Sous réserve de modifications  
 Änderungen vorbehalten  
 Modifications reserved

No.	5030.017	04
-----	----------	----



6 3/4 x 8'''



1063

**Funktionen**

**Fonctions**

**Functions**

Kaliber Calibre Caliber	Stellwellenpos. Pos. de tige Stem position	Funktionen Fonctions Functions
1063	1	Normale Position / Position normale / Running position
	2	Zeiger stellen, Sekunden-Stopp mit Unterbruch der Motorimpulse Mise à l'heure, stop-seconde avec interruption des impulsions moteur Hand setting, stop-second with interruption of motor pulses

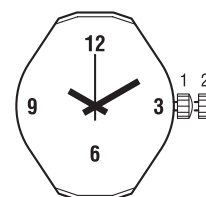

**Batterie**

**Pile**

**Battery**

Kaliber Calibre Caliber	Batterie Pile Battery	Spannung Voltage Tension	Artikelnummer RONDA Numero d'article RONDA Part number RONDA
1063	321 / SR616SW	1.55 V	3600.023.HGF

6 3/4 x 8''' 1063

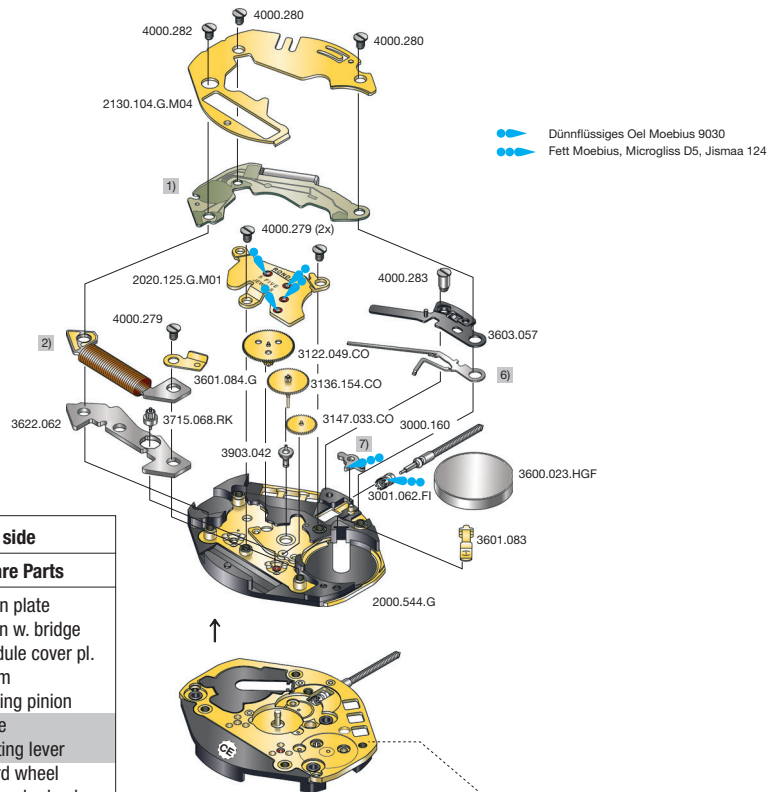

Cal. 1062	Werkseite / Côté mouvement / Movement side		
Plan No.	Bestandteile	Fournitures	Spare Parts
2000.544.G	Werkplatte	Platine	Main plate
2020.125.G.MO1	Räderwerkbrücke	Pont rouge	Train w. bridge
2130.104.G.MO4	Modul-Abdeckp.	Couvre module	Module cover pl.
3000.160	Stellwelle	Tige	Stem
3001.062.FI	Kupplungstrieb	Pignon coulant	Sliding pinion
6)	Kuppl.-triebhebel	Bascule	Yoke
7)	Winkelhebel	Tirette	Setting lever
3122.049.CO	Kleinbodenrad	Roue moyenne	Third wheel
3136.154.CO	Sekundenrad	Roue secondes	Second-wheel
3147.033.CO	Zwischenrad	Roue interméd.	Intermed. wheel
3600.023.HGF	Batterie	Pile	Battery
3601.083	Batt.-Kontakt (-)	Bride contact (-)	Batt. contact (-)
3601.084.G	Batteriehalter (+)	Bride de pile (+)	Battery clamp (+)
3603.057	Deckplatte/Ste.	Couvre mécan.	Setting lever cov.
1)	Modul	Module	Module
2)	Spule	Bobine	Coil
3622.062	Stator	Stator	Stator
3715.068.RK	Rotor	Rotor	Rotor
3903.042	Zentrumlagerrohr	Tube chaussée	Center tube
4000.279	Schraube	Vis	Screw
4000.280	Schraube	Vis	Screw
4000.282	Schraube	Vis	Screw
4000.283	Schraube	Vis	Screw

Code	Ab: <b>01</b> A partir de: <b>01</b> From: <b>01</b>	Ab Januar 2017 A partir de Jan 2017 From January 2017
------	--	---

1063 SWISS MADE & SWISS PARTS		
6)	<b>Kuppl. Triebhebel</b> <b>Bascule</b> <b>Yoke</b>	<b>3015.103</b>
7)	<b>Winkelhebel</b> <b>Tirette</b> <b>Setting lever</b>	<b>3017.068</b>

Code	2. Buchstabe ... <b>F</b> 2 <sup>ème</sup> chiffre ... <b>F</b> Second letter ... <b>F</b>	Bis Dezember 2016 Jusqu' en Décembre 2016 Until December 2016
------	--	---

1063 SWISS MADE & SWISS PARTS		
6)	<b>Kuppl. Triebhebel</b> <b>Bascule</b> <b>Yoke</b>	<b>3015.052</b>
7)	<b>Winkelhebel</b> <b>Tirette</b> <b>Setting lever</b>	<b>3017.043</b>

Die obigen 2 Teile bilden jeweils ein Paar. Deshalb sind die 2 Teile jeder Gruppe nicht einzeln gegeneinander austauschbar.

Les 2 fournitures ci-dessous forment une pair. C'est pourquoi les 2 fournitures de chaque groupe ne sont pas interchangeables.

The 2 parts mentioned above are forming a pair. Therefore the 2 parts of each group are not interchangeable.

Code: Beispiel CE / exemple CE / exemple CE  
(auf der Zifferblattseite / sur côté cadran / on dial side)

Code	2. Buchstabe: ab <b>E</b> 2 <sup>ème</sup> chiffre: à partir de <b>E</b> Second letter: from <b>E</b>	Ab Januar 2016 A partir de Janvier 2016 From January 2016
------	---	---

		1063 SWISS MADE	1063 SWISS PARTS
1)	<b>Modul (neu)</b> <b>Module (nouvelle)</b> <b>Module (new)</b>	<b>3612.262</b> gelb jaune yellow 	<b>3612.263</b> rot rouge red 
2)	<b>Spule (neu)</b> <b>Bobine (nouvelle)</b> <b>Coil (new)</b>	<b>3621.084.RK</b> gelb jaune yellow 	

Code	2. Buchstabe ... <b>D</b> 2 <sup>ème</sup> chiffre ... <b>D</b> Second letter ... <b>D</b>	Bis Dezember 2015 Jusqu' en Décembre 2015 Until December 2015
------	--	---

		1063 SWISS MADE	1063 SWISS PARTS
1)	<b>Modul (alt)</b> <b>Module (vielle)</b> <b>Module (old)</b>	<b>3612.222</b> blau bleu blue 	<b>3612.223</b> weiss blanc white 
2)	<b>Spule (alt)</b> <b>Bobine (vielle)</b> <b>Coil (old)</b>	<b>3621.027.RK</b> rot rouge red 	



Die obigen 2 Teile bilden jeweils ein Paar. Deshalb sind die 2 Teile jeder Gruppe nicht einzeln gegeneinander austauschbar.

Les 2 fournitures ci-dessous forment une pair. C'est pourquoi les 2 fournitures de chaque groupe ne sont pas interchangeables.

The 2 parts mentioned above are forming a pair. Therefore the 2 parts of each group are not interchangeable.

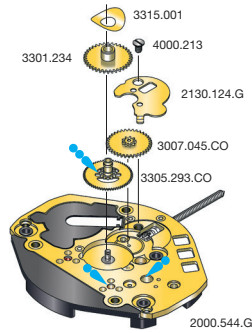
6 3/4 x 8''' 1063



 Düninflüssiges Oel Moebius 9030  
 Fett Moebius, Microgliss D5, Jismaa 124

Cal. 1063	Zifferblattseite / Côté cadran / Dial side		
Plan No.	Bestandteile	Fournitures	Spare Parts
2130.124.G	Zeigerwerkplatte	Plaque maintien	Maintaining plate
3007.045.CO	Wechselrad	Minuterie	Minute wheel
3301.234	Stundenrad	Canon	Hour wheel
3305.293.CO	Minutenrohr	Chaussée	Cannon pinion
3315.001	Spreizfeder 2 1/2	Clinquant 2 1/2	Washer 2 1/2
4000.213	Schraube	Vis	Screw

## Elektr. Messungen

## Contrôles électriques

## Electrical checking

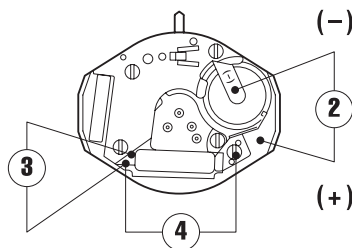
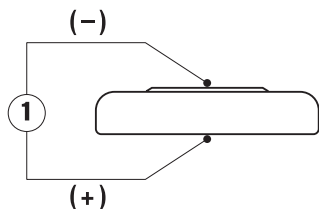

Kaliber Calibre Caliber	Pos. Pos. Pos.	Einheit Unité Unit	Messwerte Valeurs mesurées Measured values	Kontrolle Contrôle Check	Bemerkungen Remarques Remarks
1063	1	V	1,55	Batterie-Spannung Tension de la pile Battery voltage	Batterie herausnehmen und messen Enlever et mesurer la pile Remove battery for measuring
1063	2	µA	0,70–1,15	Stromaufnahme Consom. de courant Power consumption	Ohne Batterie, mit externer Speisung Sans pile, avec alimentation externe Without battery, with external power supply
1063	2	V	< 1,30	Funktionskontrolle bei Minimalspannung Contrôle de fonctionnement à tension minimale Check with lowest possible voltage	Ohne Batterie, mit externer Speisung Sans pile, avec alimentation externe Without battery, with external power supply
1063	3	KΩ	* 1,39–1,45 ** 2,70–2,90	Spulenwiderstand Résistance de la bobine Resistance of the coil	Ohne Batterie Sans pile Without batteryry
1063	4	KΩ	∞	Spulenisolation Isolation de la bobine Coil insulation	Ohne Batterie Sans pile Without battery
1063		Sek./Monat sec./mois sec./month	- 10/+ 20	Induktivsonde 60 Sek. Senseur inductif 60 sec. Inductive sensor 60 sec.	Mit Batterie Avec pile With battery

Code auf Werkplatte, 2. Buchstabe: ab **E**  
 \* Code sur platine, 2<sup>ème</sup> chiffre: à partir de **E**  
 Code on main plate, second letter: from **E**  
 Ab Januar 2016  
 A partir de Janvier 2016  
 From January 2016

Code auf Werkplatte, 2. Buchstabe ... **D**  
 \*\* Code sur platine, 2<sup>ème</sup> chiffre ... **D**  
 Code on main plate, second letter ... **D**  
 Bis Dezember 2015  
 Jusqu' en Décembre 2015  
 Until December 2015

## Einschalen / Werkzeuge

## Emboîtement / outils

## Casing / tools

Nr. H 106X.1A



Nr. H 106X.1T



	SWISS MADE ⊕ 6h		SWISS PARTS ⊕ 6h	
1062	–	–	–	–
1063		–		–
1064	–		–	
1069	–	–	–	–

### Zeigersetzen

Maximale Aufpresskraft:

– Stunden und Minutenzeiger: max. 40N

– Sekundenzeiger: max. 30N

Beim Zeigersetzen muss das Werk abgestützt werden.

### Poser les aiguilles

Force de chassage maximale:

– Aiguilles des heure et des minutes: max. 40N

– Aiguille des secondes: max. 30N

Lors de la pose d'aiguilles, le mouvement doit être soutenu.

### Hand setting

Maximal force:

– Hour and minute hands: max. 40N

– Second hand: max. 30N

The movement needs to be supported for hand setting.

### Stellwelle entfernen

Beim Entfernen der Stellwelle muss sich die Stellwelle in Position 1 (gedrückt) befinden, bevor auf den Winkelhebel gedrückt wird.

### Enlever la tige

En enlevant la tige, la tige doit se trouver en position 1 (poussée), avant de pousser sur la tirette.

### Stem removal

For removal of the stem, the stem must be pushed into position 1 (pressed in) prior to apply pressure to the setting lever.