

Quartz Movements

Classic Functions

RONDA powertech

CALIBER 515 – 11½"



Product Specifications

Analog quartz movement

Line	powertech
Caliber	515
Size	11½"
Version Swiss Made	1 Jewels / nickel plated
Version Swiss Parts	1 Jewels / nickel plated
Standard battery life	45 months
High battery life	60 months
Standard hand fitting height	1

Functions

- Date
- 3 hands

Features

- Repairable metal watch movement
- Power saving mechanism with pulled out stem:
Reduction of consumption approximately 70%
- Interchangeability: All versions 11½" with same
movement height 3.00 mm and stem height 1.50 mm
- Very powerful stepping motor

CALIBER 515 – 11½"

Technical Specifications

Diameter Total	26.00 mm
Case fitting	25.60 mm
Movement height	3.00 mm
Height over standard battery	3.25 mm
Height over high battery	0.00 mm
Movement rest	0.80 mm
Height over stem	1.50 mm
Length of stem travel	1.00 mm
Stem thread	0.90 mm
Useful torque second – typical	9 µNm
Useful torque minute – typical	400 µNm
Operating temperature	0 - 50 °C
Instantaneous rate	-10/ +20 sec/month
Resistance to magnetic fields	18.8 Oe
Resistance against shock	NIHS 91-10

Battery Specifications

Standard battery	No. 371
High battery	No. 395
Standard battery life	45 months
High battery life	60 months
Battery voltage	1.5 V
Current consumption – typical	1.28 µA (Date Mechanism not in Gear)
Current consumption – maximum	1.85 µA (Date Mechanism not in Gear)

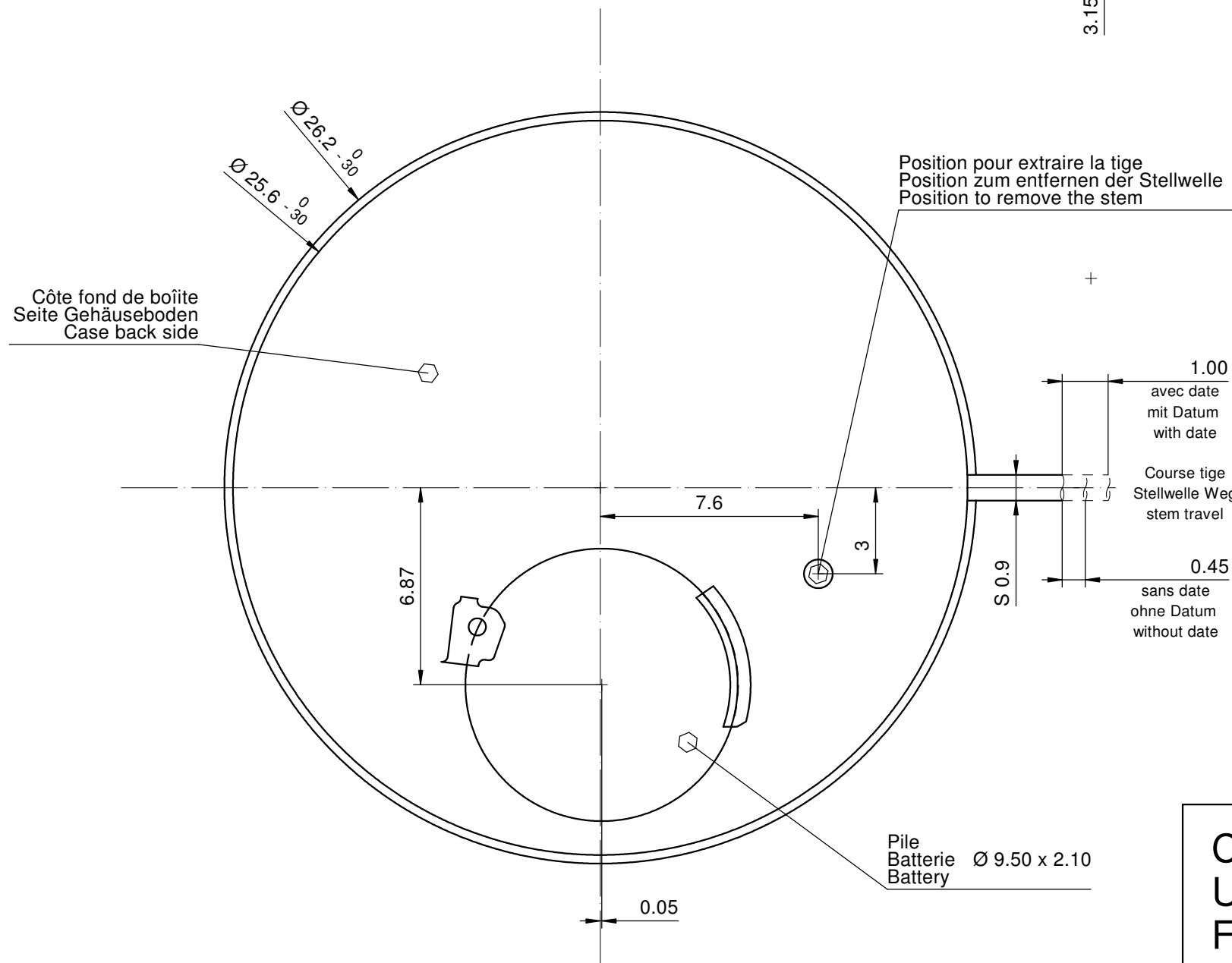
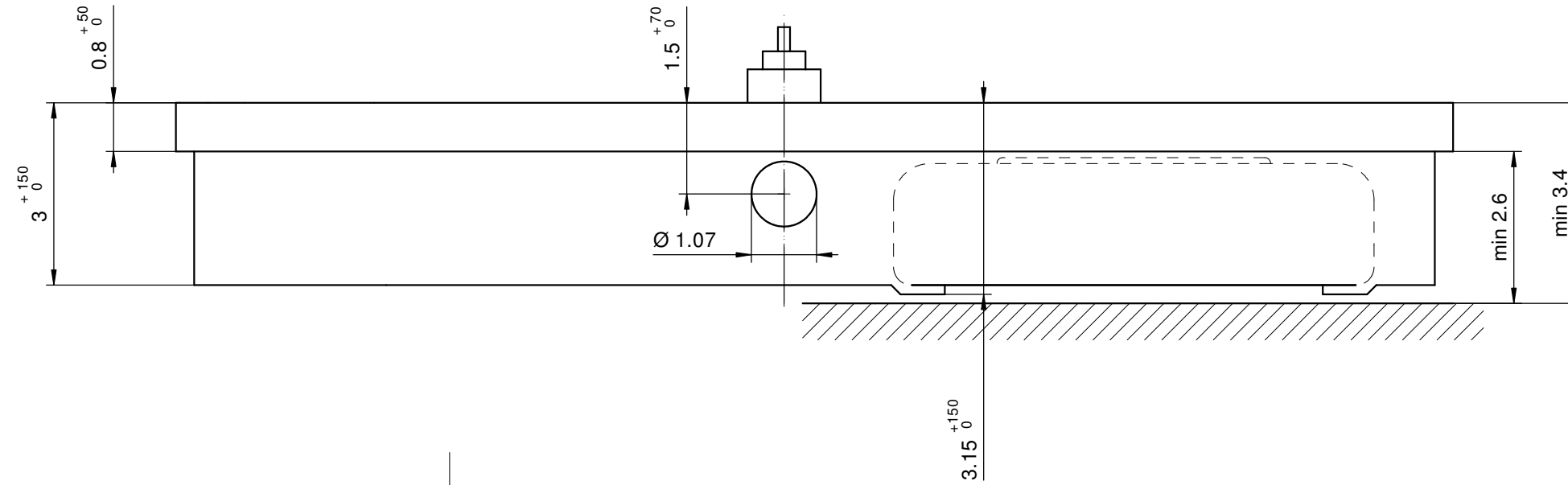

Sécurité entre aiguille seconde et verre : min 0.30 mm
Sicherheit zwischen Sekundenzeiger und Glas : min 0.30 mm
Security between second hand and glass : min 0.30 mm

Le cadran doit être maintenu en hauteur par la boîte.
Das Zifferblatt muss in der Höhe vom Gehäuse festgehalten werden.
The dial must be held in the height by the case.

Cage Uhrwerkgestell 11½" Frame

RONDA

512, 513, 513S, 515, 515S
517, 517S, 519, 519S

Issued	10.03.1999	gd
Modified	06.06.2018	ds5222
Released	YES	
Mod. No.	38099	
Tolerance	±20 µm	
Scale	10 : 1	Page 1/1 A3
Sous réserve de modifications Aenderungen vorbehalten Modifications reserved		
No.	5000.286	09

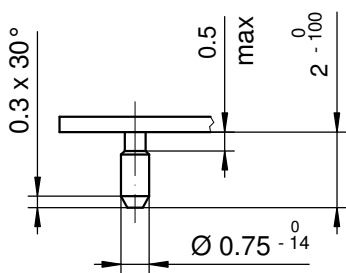
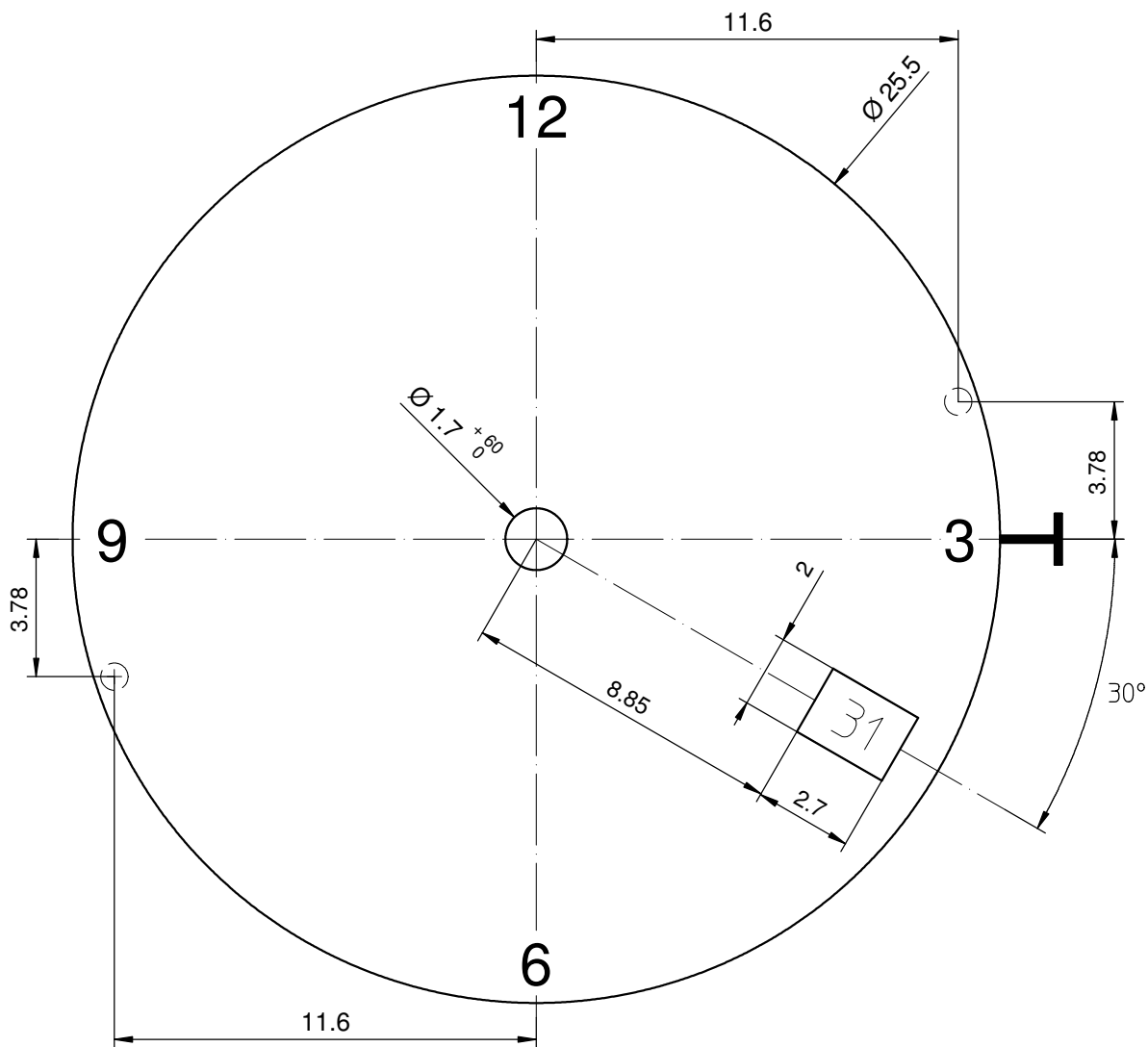

Epaisseur du cadran selon hauteur de l'aiguillage
 Zifferblattdicke gemäss Zeigerwerkhöhen
 Dial thickness according to hand fitting heights

Tige	Date
Stellw.	Datum
Stem	Date
3H	4H

Cadran Zifferblatt Dial	11½"	Issued	05 Jun 2007	cm
		Modified	13 Aug 2012 ÄA 12806	mc
		Released	YES	
		Tolerance	+/- 20 µm	
		Scale	5 : 1 (A4V)	
RONDA	515, 515S, 714, 715, 715Li	Sous réserve de modifications Aenderungenvorbehalten Modificationsreserved		
		No.	5010.377	02

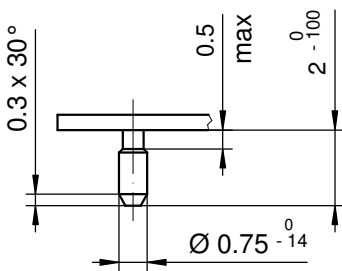
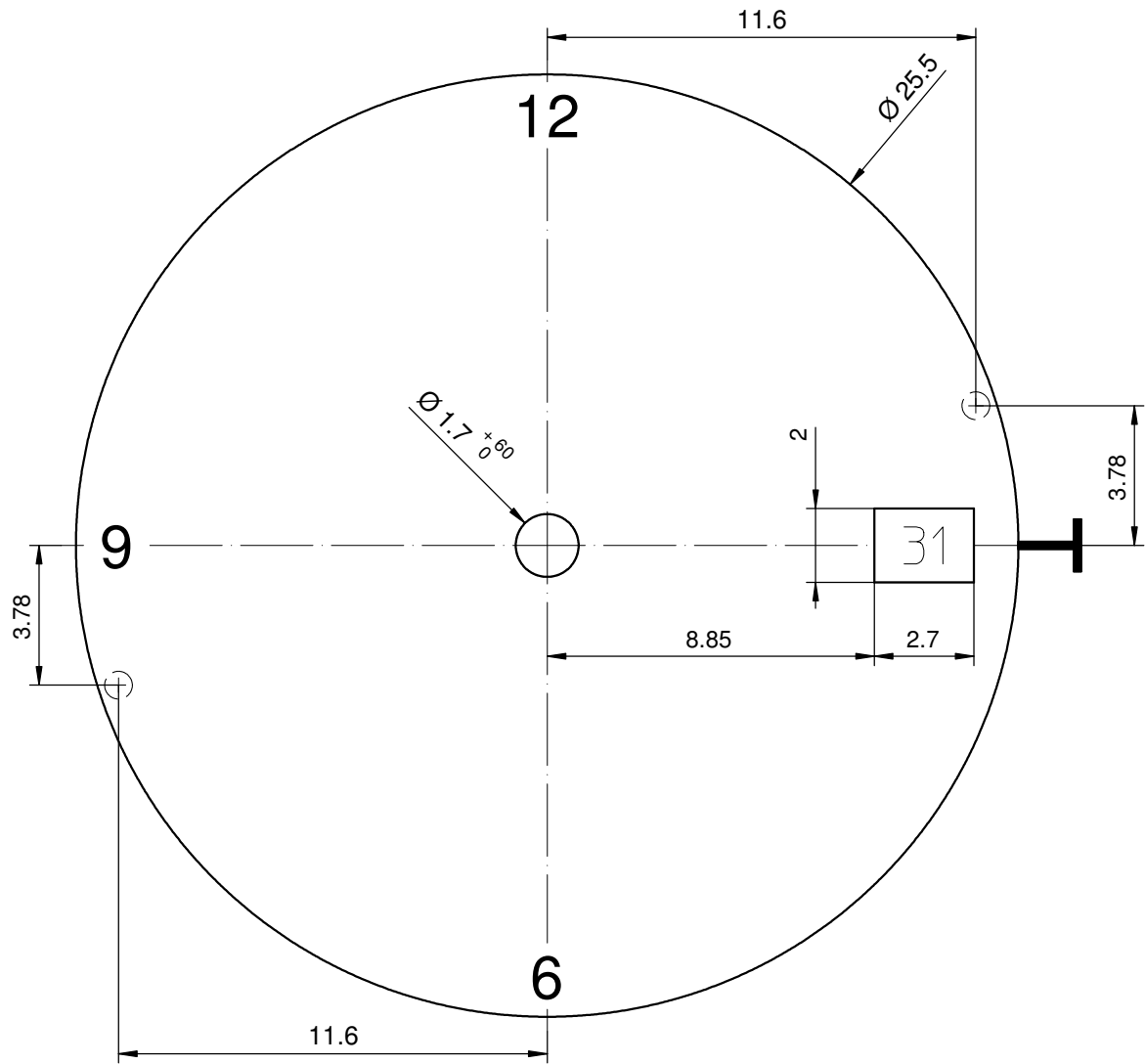

Epaisseur du cadran selon hauteur de l'aiguillage
 Zifferblattdicke gemäss Zeigerwerkhöhen
 Dial thickness according to hand fitting heights

Tige	Date
Stellw.	Datum
Stem	Date
3H	3H

Cadran Zifferblatt Dial	11½"	Issued	14 Dez 2006	cw
		Modified	13 Aug 2012 ÄA 12806	mc
		Released	YES	
		Tolerance	+/- 20 µm	
		Scale	5 : 1 (A4V)	
RONDA	515, 515S, 714, 715, 715Li	Sous réserve de modifications Aenderungenvorbehalten Modificationsreserved		
		No.	5010.417	09

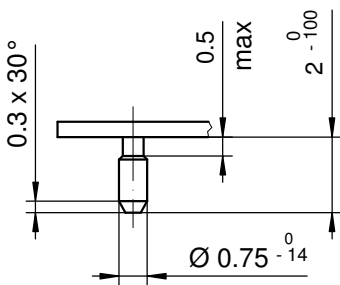
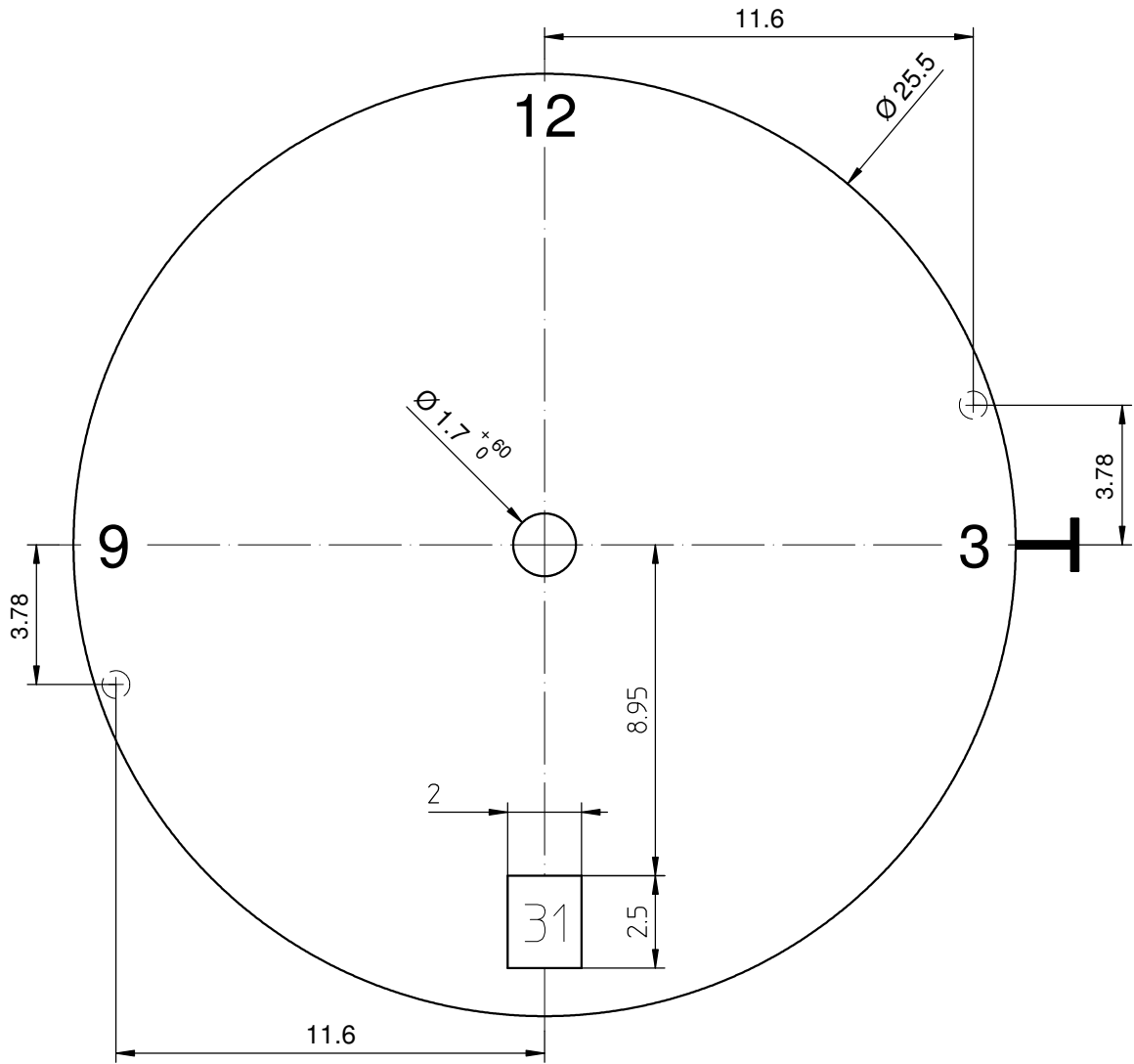

Epaisseur du cadran selon hauteur de l'aiguillage
 Zifferblattdicke gemäss Zeigerwerkhöhen
 Dial thickness according to hand fitting heights

Tige	Date
Stellw.	Datum
Stem	Date
3H	6H

Cadran Zifferblatt Dial	11½"	Issued	14 Dez 2006	cw
		Modified	13 Aug 2012 ÄA 12806	mc
		Released	YES	
		Tolerance	+/- 20 µm	
		Scale	5 : 1 (A4V)	
RONDA	515, 515S, 714, 715, 715Li	Sous réserve de modifications Aenderungenvorbehalten Modificationsreserved		
		No.	5010.467	07

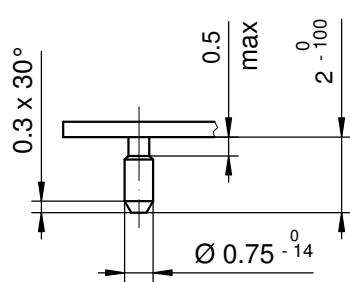
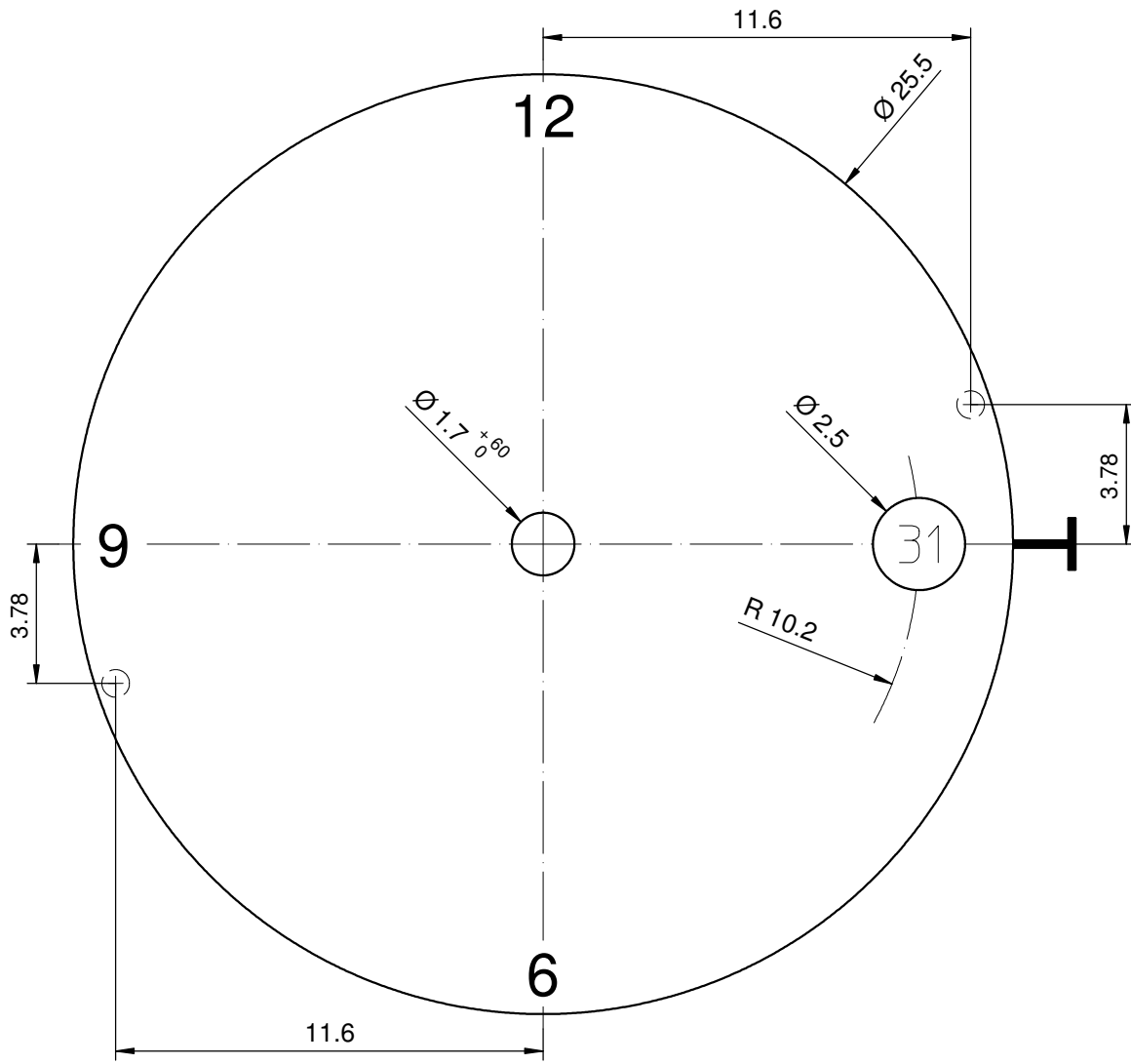

Epaisseur du cadran selon hauteur de l'aiguillage
 Zifferblattdicke gemäss Zeigerwerkhöhen
 Dial thickness according to hand fitting heights

Tige	Date
Stellw.	Datum
Stem	Date
3H	3H
○	

Cadran Zifferblatt Dial	11½"	Issued	14 Dez 2006	cw
		Modified	13 Aug 2012 ÄA 12806	mc
		Released	YES	
		Tolerance	+/- 20 µm	
		Scale	5 : 1 (A4V)	
RONDA	515, 515S, 714, 715, 715Li	Sous réserve de modifications Aenderungenvorbehalten Modificationsreserved		
		No.	5010.477	06

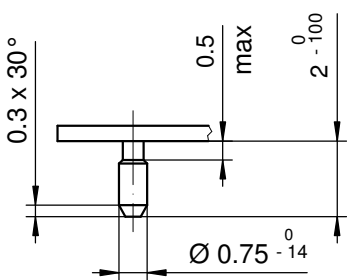
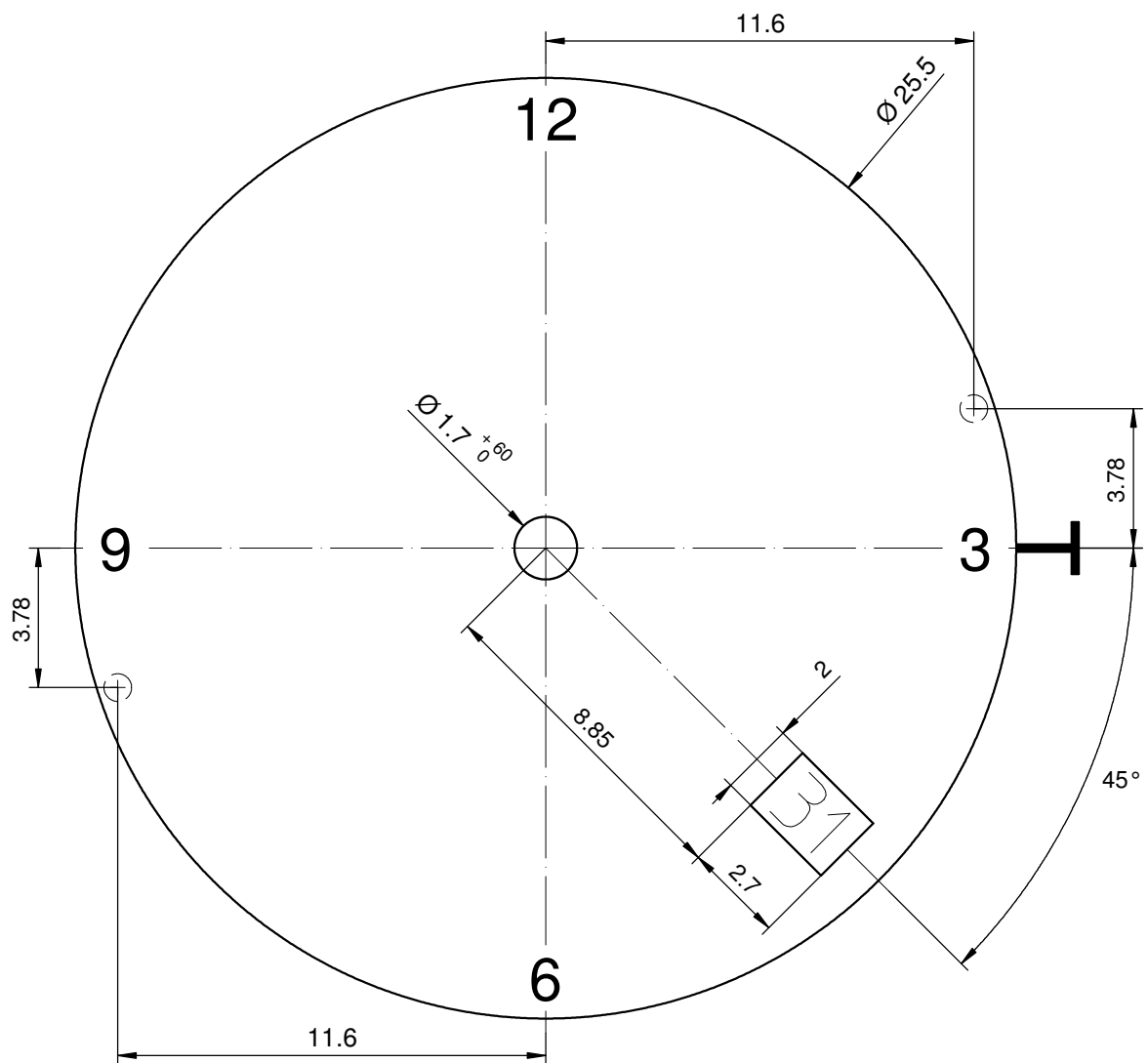

Epaisseur du cadran selon hauteur de l'aiguillage
 Zifferblattdicke gemäss Zeigerwerkhöhen
 Dial thickness according to hand fitting heights

Tige	Date
Stellw.	Datum
Stem	Date
3H	4½H

Cadran Zifferblatt Dial	11½"	Issued	14 Dez 2006	cw
		Modified	13 Aug 2012 ÄA 12806	mc
		Released	YES	
		Tolerance	+/- 20 µm	
		Scale	5 : 1 (A4V)	
RONDA	515, 515S, 714, 715, 715Li	Sous réserve de modifications Aenderungenvorbehalten Modificationsreserved		
		No.	5010.580	04

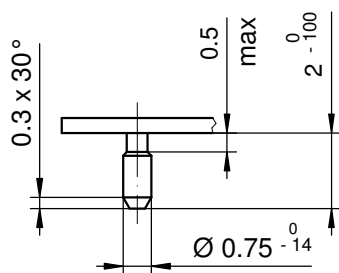
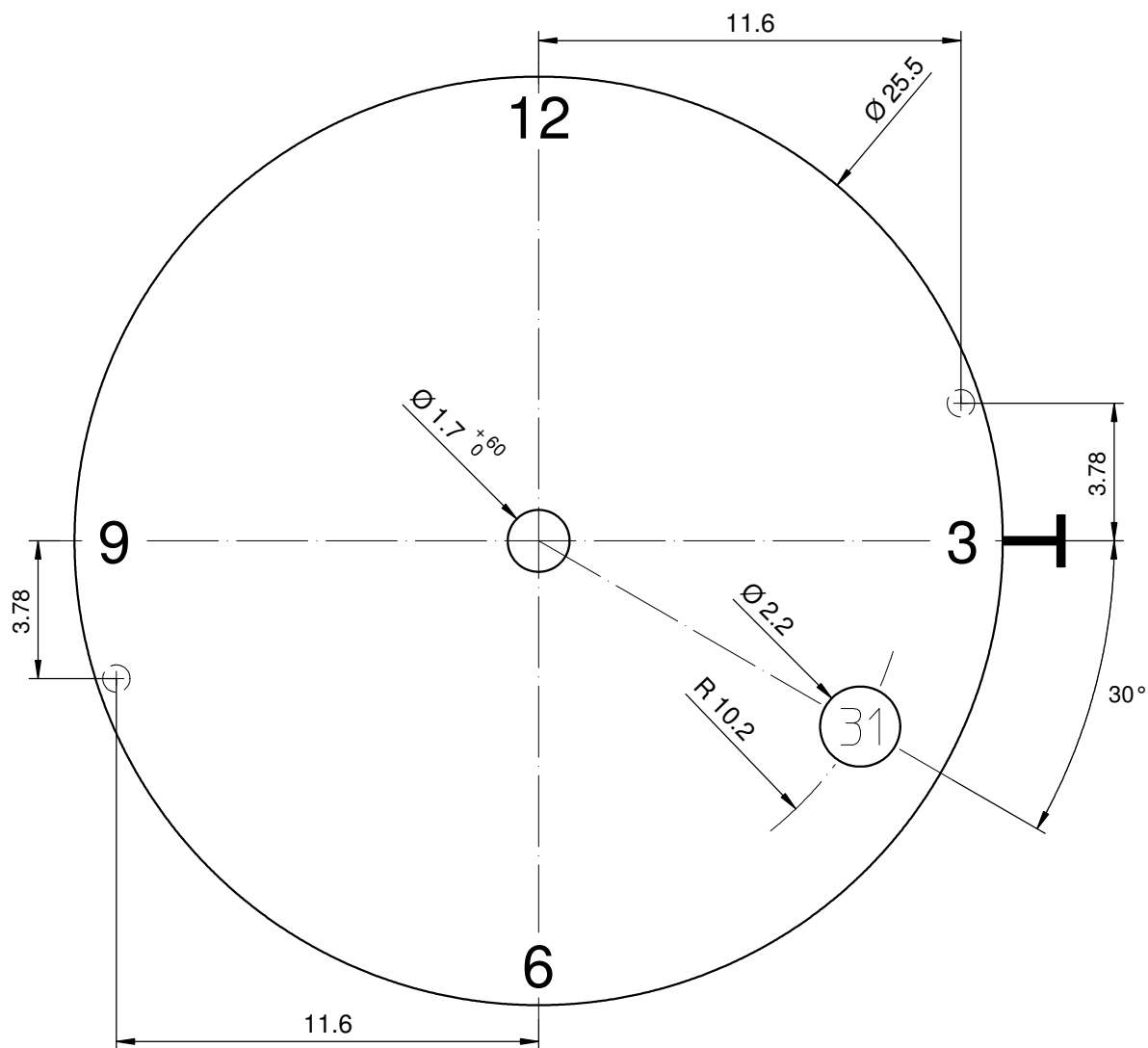

Epaisseur du cadran selon hauteur de l'aiguillage
 Zifferblattdicke gemäss Zeigerwerkhöhen
 Dial thickness according to hand fitting heights

Tige	Date
Stellw.	Datum
Stem	Date
3H	4H
○	

Cadran
Zifferblatt 11 1/2"
Dial

Issued	14 Dez 2006	cw
Modified	31 Mai 2013 ÄA 13427	dh
Released	YES	
Tolerance	+/- 20 µm	
Scale	5 : 1 (A4V)	

RONDA

515, 515S, 714, 715, 715Li

Sous réserve de modifications
 Aenderungenvorbehalten
 Modifications reserved

No.	5010.615	05
-----	----------	----

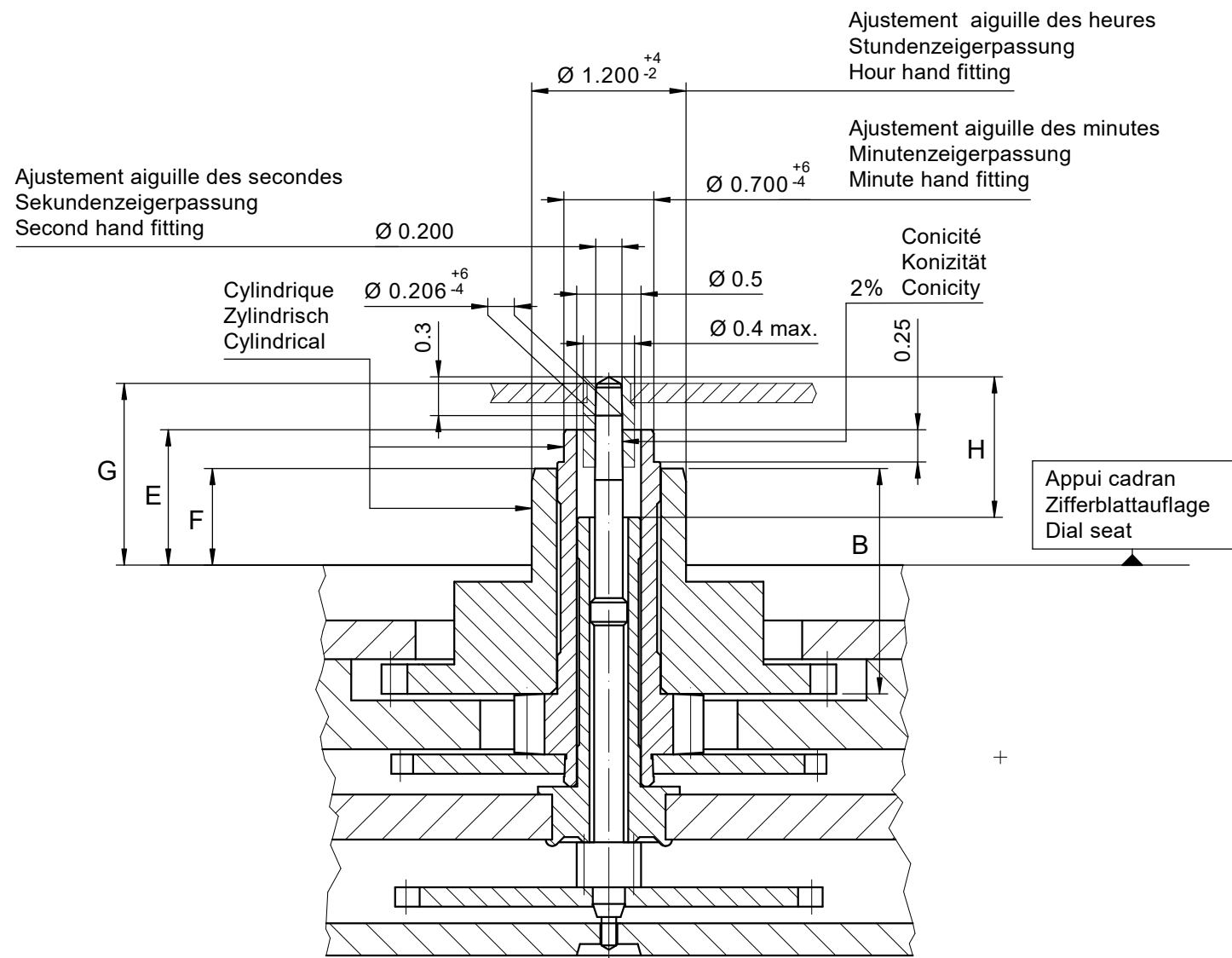

Heures / minutes / secondes
 Stunden / Minuten / Sekunden
 Hours / minutes / seconds

Aiguillage no Zeigerwerkhöhe Nr. Hand fitting height No	Dépassement Höhe über Zifferblattauflage Height over dial seat			Longueur Länge Length		Epaisseur max. (peinture comprise) Max. thickness (inkl. Farbe) Max. thickness (paint included)					
	Pignon des secondes Sekundentrieb Second pinion	Chaussée Minutenrohr Cannon-pinion	Roue des heures Stundenrad Hour wheel	Roue des heures Stundenrad Hour wheel	B	H	Sous l'aiguille des secondes Unter Sekundenzeiger Under second hand	Cadran Zifferblatt Dial	Sous l'aiguille des minutes Unter Minutenzeiger Under minute hand	Sous l'aiguille des heures Unter Stundenzeiger Under hour hand	Aiguilles Zeiger Hands
1	1.46	1.05	0.75	1.09	1.75	0.95	0.65	0.40	0.15		
2	1.81	1.40	1.10	1.44	2.10	1.30	1.00	0.75	0.15		

	Aig. des secondes Sekundenzeiger Second hand	Aig. des minutes Minutenzeiger Minute hand	Aig. des heures Stundenzeiger Hour hand	Lors de la pose d'aiguilles, le mouvement doit être soutenu. Beim Zeigersetzen muss das Werk abgestützt werden. The movement needs to be supported for hand setting.
mg max.	10	30	30	Masse / Masse / Weight *
µNm max.	0.08	0.70	0.70	Balourd / Unwucht / Unbalance *
gmm ² max.	0.4	-	-	Inertie / Massenträgheit / Inertia *
N max.	30	40	40	Force de chassage / Aufpresskraft / Force

Aiguillages Zeigerwerkhöhen 10½", 11½" Hand fitting heights		Issued	10.03.1999	gd
		Modified	24.02.2022	jk5228
RONDA 503, 513, 505, 515		Released	YES	
		Mod. No.	44909	
		Tolerance	---	
		Scale	10 : 1	Page 1/1
		Sous réserve de modifications Änderungen vorbehalten Modifications reserved		
No.	3316.059	10		

* En cas de données différentes, veuillez contacter le service après-vente * Bei abweichenden Werten, bitte technischen Kundendienst anfragen * In case of different values, please contact the customer service

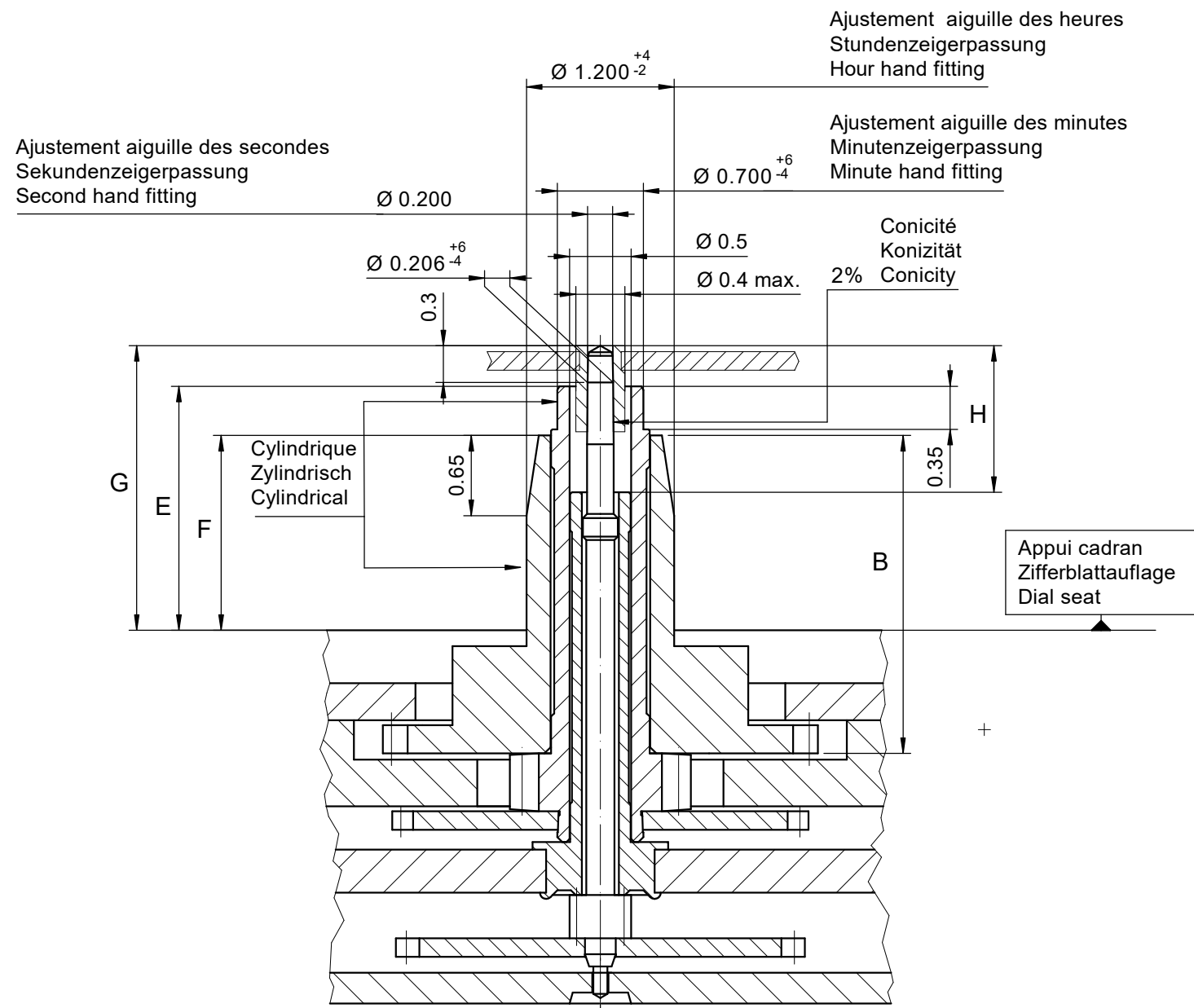

Heures / minutes / secondes
 Stunden / Minuten / Sekunden
 Hours / minutes / seconds

	Aig. des secondes Sekundenzeiger Second hand	Aig. des minutes Minutenzeiger Minute hand	Aig. des heures Stundenzeiger Hour hand	Lors de la pose d'aiguilles, le mouvement doit être soutenu. Beim Zeigersetzen muss das Werk abgestützt werden. The movement needs to be supported for hand setting.
mg max.	10	30	30	Masse / Masse / Weight *
µNm max.	0.08	0.70	0.70	Balourd / Unwucht / Unbalance *
gmm ² max.	0.4	-	-	Inertie / Massenträgheit / Inertia *
N max.	30	40	40	Force de chassage / Aufpresskraft / Force

Aiguillage no Zeigerwerkhöhe Nr. Hand fitting height No	Dépassement Höhe über Zifferblattauflage Height over dial seat			Longueur Länge Length		Epaisseur max. (peinture comprise) Max. thickness (inkl. Farbe) Max. thickness (paint included)			
	Pignon des secondes Sekundentrieb Second pinion	Chausée Minutenrohr Cannon-pinion	Roue des heures Stundenrad Hour wheel			Cadran Zifferblatt Dial		Aiguilles Zeiger Hands	
	G	E	F	H	B	Sous l'aiguille des secondes Unter Sekundenzeiger Under second hand	Sous l'aiguille des minutes Unter Minutenzeiger Under minute hand	Sous l'aiguille des heures Unter Stundenzeiger Under hour hand	
6	2.31	1.98	1.58	1.19	2.58	1.80	1.55	0.40	0.15

Aiguillages
Zeigerwerkhöhen 10½", 11½"
Hand fitting heights

RONDA 503, 505, 513, 515

Issued	10.03.1999	gd
Modified	24.02.2022	jk5228
Released	YES	
Mod. No.	44909	
Tolerance	---	
Scale	10 : 1	Page 1/1 A3
Sous réserve de modifications Änderungen vorbehalten Modifications reserved		
No.	3316.067	05

* En cas de données différentes, veuillez contacter le service après-vente

* Bei abweichenden Werten, bitte technischen Kundendienst anfragen

* In case of different values, please contact the customer service

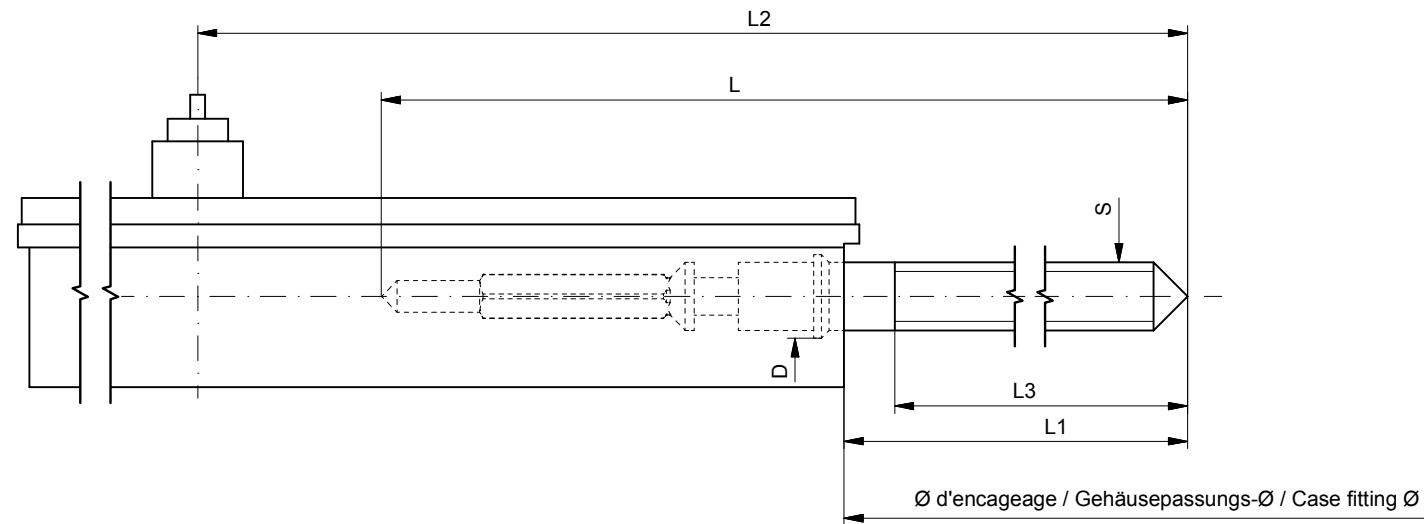

Tige de travail (intégrée dans le mouvement)
 Arbeitstellwelle (im Werk eingebaut)
 Working stem (implemented in the movement)

No. d'article Artikelnummer Part number	L	L1	L2	L3	S	D
3000.164.CO	20.50	9.92	22.72	11.83	0.90	1.05

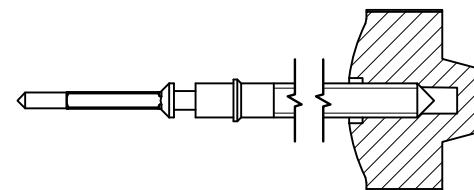

Couleur de la couronne Kronenfarbe Crown color	brun braun brown
Code	UN 8052

Tige (normale) / Stellwelle (normal) / Stem (normal)

No. d'article Artikelnummer Part number	L	L1	L2	L3	S	D
3000.164	20.50	9.92	22.72	11.83	0.90	1.05
3000.171	32.50	21.92	34.72	23.83	0.90	1.05

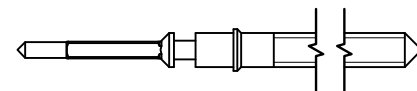

Tige (à arracher)
 Stellwelle (Ausreissversion)
 Stem (extractable version)

No. d'article Artikelnummer Part number	L	L1	L2	L3	S	D
3000.163	20.50	9.92	22.72	11.83	0.90	1.05
3000.196	32.50	21.92	34.72	23.83	0.90	1.05

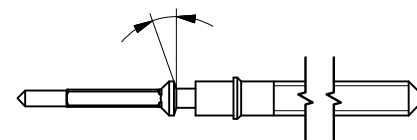

Rallonge de tige / Stellwelle Verlängerung / Stem extension

No. d'article Artikelnummer Part number	L4	L5 (min)	L6	S1	S2	D1
3000.040	12.00	1.90	2.60	0.90	0.90	1.35

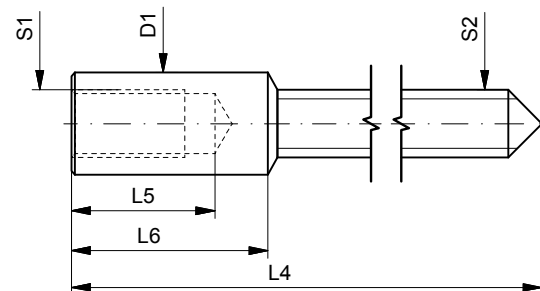

Couronne normale
 Normale Krone
 Normal crown

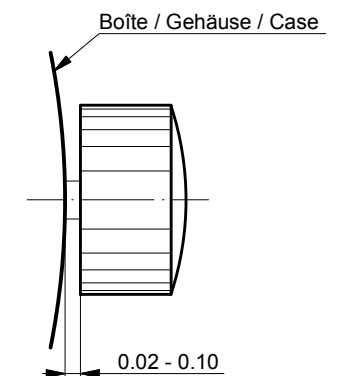

Couronne vissée
 Geschraubte Krone
 Screwed crown

Force ⇐ min. Kraft ⇐ min. Force ⇐ min.	10 N
Force ⇐ max. Kraft ⇐ max. Force ⇐ max.	15 N

Tige (dimensions / forces)
 Stellwelle (Dimensionen / Kräfte)
 Stem (dimensions / forces)

RONDA

512, 513, 513S, 515, 515S, 515.24H,
 515.24D, 517, 517S, 519, 519S

Issued	15.08.2012	ds5222
Modified	29.06.2018	ds5222
Released	YES	
Mod. No.	38099	
Tolerance	---	
Scale	---	Page 1 / 1 A3

Sous réserve de modifications
 Änderungen vorbehalten
 Modifications reserved

No.	5030.002	02
-----	----------	----

Cal. 585	Cal. 6003.D
Cal. 505	Cal. 6004.D
Cal. 515	Cal. 6003.B
	Cal. 6004.B



RONDA powertech

- 585
- 505
- 515

RONDA slimtech

- 1005
- 1006
- 1009
- 1015
- 1016
- 1019

RONDA normtech

- 774 - 6003.D
- 775 - 6004.D
- 704
- 705
- 784
- 785
- 714
- 715
- 715Li

RONDA xtratech

- 6003.B
- 6004.B
- 7002.B
- 7003.B
- 7004.B

Pos. I Position of rest (watch running)

Pos. II Quick-change correction for date

The date can also be corrected during the day-changing phase between 10 pm and midnight. The date of the following day has to be set, because no automatic date change takes place at midnight.

- Pull the crown out to position II (watch still running).
- Turn the crown clockwise until the required date appears.
- Cal. 6003.D & 6004.D:*
- Turn the crown until the required date appears.
- Push the crown back into position I.

Pos. III Setting the time

- Pull the crown out to position III (watch stopped).
- Turn the crown, until the current time is displayed (remember the 24-hour cycle).
- Push the crown back into position I.

Cal. 774	Cal. 715Li
Cal. 775	
Cal. 704	Cal. 1005
Cal. 705	Cal. 1006
Cal. 784	Cal. 1009
Cal. 785	Cal. 1015
Cal. 714	Cal. 1016
Cal. 715	Cal. 1019



Pos. I Position of rest (watch running)

Pos. II Quick-change correction for date

Blocking time for the quick-change day correction is from approx. 9.30 pm and midnight.

- Pull the crown out to position II (watch still running).
- Turn the crown until the current date appears.
- Push the crown back into position I.

Pos. III Setting the time

- Pull the crown out to position III (watch stopped).
- Turn the crown, until the current time is displayed (remember the 24-hour cycle).
- Push the crown back into position I.

You have decided to buy a watch, which was assembled by a watchmaker using a Ronda movement. Please note that no watches are produced or distributed under the Ronda brand.

In case of repairs, guarantee claims and questions concerning the functioning of a watch, purchasers and consumers should contact their retailer or the watch manufacturer, for which the relevant information can be found in the sales or guarantee documentation provided with the watch.

Cal. 7002.B
Cal. 7003.B
Cal. 7004.B

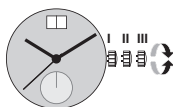

Pos. I Position of rest (watch running)

Pos. II Quick-change correction for date

The date can also be changed during the day-changing phase between approx. 8.00 pm and midnight. The date of the following day has to be set, because no automatic date change takes place at midnight.

- Pull the crown out to position II (watch still running).
- Turn the crown until the current date appears.
- Push the crown back into position I.

Pos. III Setting the time

- Pull the crown out to position III (watch stopped).
- Turn the crown, until the current time is displayed (remember the 24-hour cycle).
- Push the crown back into position I.

Cal. 585 / 785:

Battery type: 362/SR721SW

Cal. 774 / 775 / 784:

Battery type: 364/SR621SW

Cal. 505 / 515 / 704 / 705 / 714 / 715:

Battery type: 371/SR920SW

Cal. 6003.D / 6004.D / 6003.B / 6004.B:

Battery type: 373/SR916SW

Cal. 1005 / 1006 / 1009 / 1015 / 1016 / 1019:

Battery type: 341/SR714SW

Cal. 7002.B / 7003.B / 7004.B:

Battery type: 381/SR1120SW

Cal. 715Li:

Battery type: CR 2016

Precision: +20/-10 seconds per month



11 1/2^{mm}



512

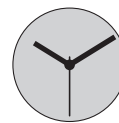

513

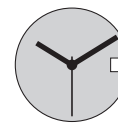

515

Funktionen

Fonctions

Functions

Kaliber	Stellwellenpos.	Funktionen
Calibre	Pos. de tige	Fonctions
Caliber	Stem position	Functions
512, 513	1	Normale Position / Position normale / Running position
	2	Zeiger stellen, Sekunden-Stopp mit Unterbruch der Motorimpulse Mise à l'heure, stop-seconde avec interruption des impulsions moteur Hand setting, stop-second with interruption of motor pulses
515	1	Normale Position / Position normale / Running position
	2	Datumskorrektur / Correction de la date / Date correction
	3	Zeiger stellen, Sekunden-Stopp mit Unterbruch der Motorimpulse Mise à l'heure, stop-seconde avec interruption des impulsions moteur Hand setting, stop-second with interruption of motor pulses

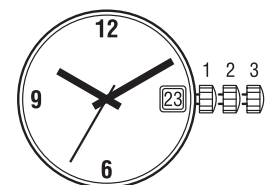

Batterie

Pile

Battery

Kaliber	Batterie	Spannung	Artikelnummer RONDA
Calibre	Pile	Voltage	Numero d'article RONDA
Caliber	Battery	Tension	Part number RONDA
512, 513, 515	371/SR920SW	1.55 V	3600.015.HGF

11 1/2''' 512, 513, 515

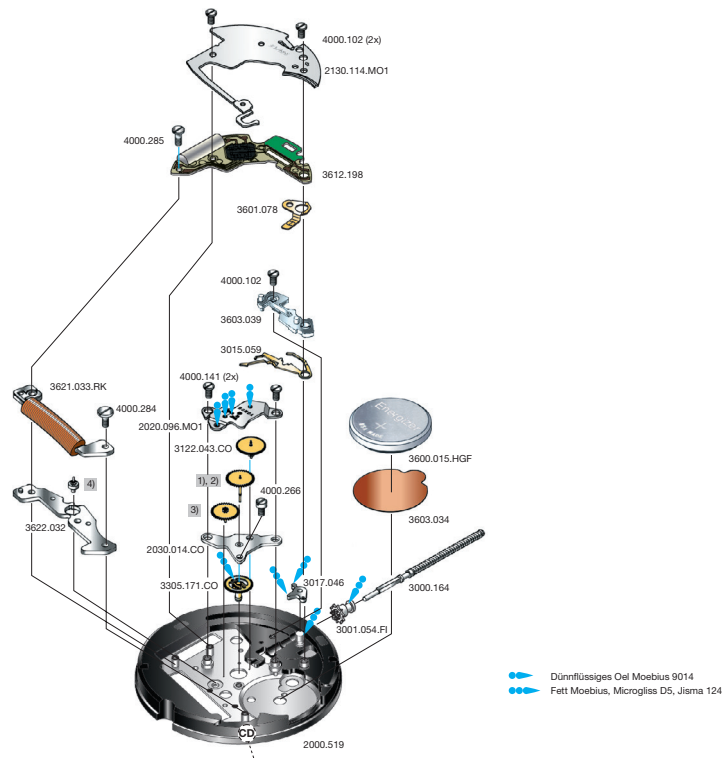

Code: Beispiel CD / exemple CD / exemple CD

Cal. 513	Werkseite / Côté mouvement / Movement side		
Plan No.	Bestandteile	Fournitures	Spare Parts
2000.519	Werkplatte	Platine	Main plate
2020.096.MO1	Räderwerkbrücke	Pont rouge	Train w. bridge
2030.014.CO	Zentrumbrücke	Pont centre	Centre bridge
2130.114.MO1	Modul-Abdeckp.	Couvre module	Module cover pl.
3000.164	Stellwelle	Tige	Stem
3001.054.FI	Kupplungstrieb	Pignon coulant	Sliding pinion
3015.059	Kuppl.-triebhebel	Bascule	Yoke
3017.046	Winkelhebel	Tirette	Setting lever
3122.043.CO	Kleinbodenrad	Roue moyenne	Third wheel
1)	Sekundenrad	Roue secondes	Second-wheel
3)	Zwischenrad	Roue interméd.	Intermed. wheel
3305.171.CO	Minutenrohr	Chaussée	Cannon pinion
3600.015.HGF	Batterie	Pile	Battery
3601.078	Batterie-Kontakt	Bride contact	Battery contact
3603.034	Batterie-Isolation	Isolateur pile	Battery insulation
3603.039	Deckplatte/ Ste.	Couvre mécan.	Setting lev. cover
3612.198	Modul	Module	Module
3621.033.RK	Spule	Bobine	Coil
3622.032	Stator	Stator	Stator
4)	Rotor	Rotor	Rotor
4000.102	Schraube	Vis	Screw
4000.141	Schraube	Vis	Screw
4000.266	Schraube	Vis	Screw
4000.284	Schraube	Vis	Screw
4000.285	Schraube	Vis	Screw

Abweichungen / Divergences / Deviations

Cal. 515	Werkseite / Côté mouvement / Movement side		
Plan No.	Bestandteile	Fournitures	Spare Parts
3015.060	Kuppl.-triebhebel	Bascule	Yoke

Cal. 512	Werkseite / Côté mouvement / Movement side		
Plan No.	Bestandteile	Fournitures	Spare Parts
2030.012.CO	Zentrumbrücke	Pont centre	Centre bridge
2)	Sekundenrad	Roue secondes	Second-wheel
3)	Zwischenrad	Roue interméd.	Intermed. wheel
3305.210.CO	Minutenrohr	Chaussée	Cannon pinion
4)	Rotor	Rotor	Rotor

Cal. 513, 515		
	Bis Juni 2015 Jusqu' en Juin 2015 Untill June 2015	Ab Juli 2015 A partir de Juillet 2015 From July 2015
Code	2. Buchstabe ... C Second letter ... C 2 ^{ème} chiffre: ... C	2. Buchstabe: ab D Second letter: from D 2 ^{ème} chiffre: à partir de D
1)	3136.090.CO	3136.194.CO
3)	3147.019.CO	3147.092.CO
4)	3715.089.RK	3715.144.RK

Die obigen 3 Teile bilden jeweils eine Gruppe. Deshalb sind die 3 Teile jeder Gruppe nicht einzeln gegeneinander austauschbar.

Les 3 fournitures ci-dessous forment un groupe individuel. C'est pourquoi les 3 fournitures de chaque groupe ne sont pas interchangeables.

The 3 parts mentioned above are forming an individual group. Therefore the 3 parts of each group are not interchangeable.

Cal. 512		
	Bis Juni 2015 Jusqu' en Juin 2015 Untill June 2015	Ab Juli 2015 A partir de Juillet 2015 From July 2015
Code	2. Buchstabe ... C Second letter ... C 2 ^{ème} chiffre: ... C	2. Buchstabe: ab D Second letter: from D 2 ^{ème} chiffre: à partir de D
2)	3136.093.CO	3136.196.CO
3)	3147.019.CO	3147.092.CO
4)	3715.089.RK	3715.144.RK

Die obigen 3 Teile bilden jeweils eine Gruppe. Deshalb sind die 3 Teile jeder Gruppe nicht einzeln gegeneinander austauschbar.

Les 3 fournitures ci-dessous forment un groupe individuel. C'est pourquoi les 3 fournitures de chaque groupe ne sont pas interchangeables.

The 3 parts mentioned above are forming an individual group. Therefore the 3 parts of each group are not interchangeable.

Werkaufbau

Assemblage

Assembling

11 1/2''' 515

11 1/2''' 512, 513

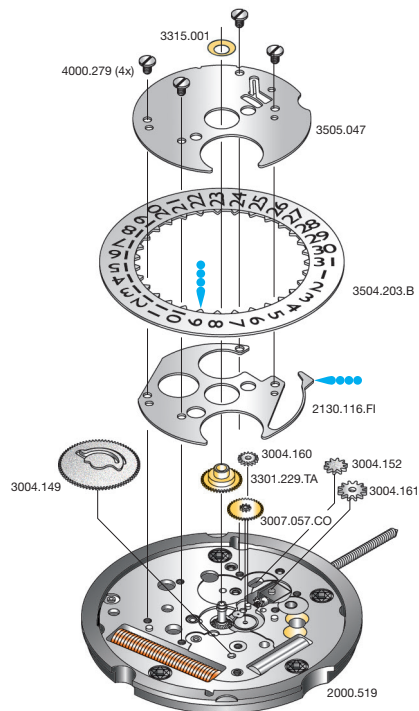

●●●●● Fett Moebius, Microgliss 14

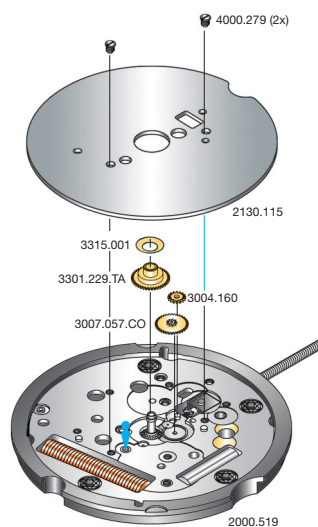

● Düninflüssiges Oel Moebius 9014

Cal. 515	Zifferblattseite / Côté cadran / Dial side		
Plan No.	Bestandteile	Fournitures	Spare Parts
2130.116.FI	Kalenderplatte	Plaque calendrier	Date ind. plate
3004.149	Datummitn.-rad	Renvoi entraî.	Ind. driving wheel
3004.152	Umkehrad	Baladeur	Sliding gear
3004.160	Zeigerstellrad	Renvoi minuterie	Setting wheel
3004.161	Verbindungsrad-Kupplungtrieb	Renvoi pig. coulant	Sliding pinon setting wheel
3007.057.CO	Wechselrad	Minuterie	Minute wheel
3301.229.TA	Stundenrad	Canon	Hour wheel
3315.001	Spreizfeder	Clinquant	Washer
3504.203.B	Datumanzeiger	Bague	Date indicator
3505.047	Kal.-Abdeckplatte	Couvercle calend.	Date ind. cover
4000.279	Schraube	Vis	Screw

Cal. 512, 513	Zifferblattseite / Côté cadran / Dial side		
Plan No.	Bestandteile	Fournitures	Spare Parts
2130.115	Zeigerwerkplatte	Plaque maintien	Maintening plate
3004.160	Zeigerstellrad	Renvoi minuterie	Setting wheel
3007.057.CO	Wechselrad	Minuterie	Minute wheel
3301.229.TA	Stundenrad	Canon	Hour wheel
3315.001	Spreizfeder	Clinquant	Washer
4000.279	Schraube	Vis	Screw

Elektr. Messungen

Contrôles électriques

Electrical checking

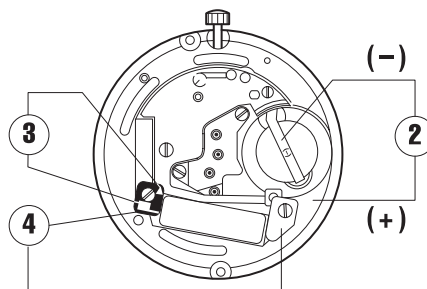
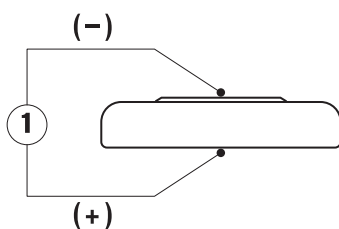

Kaliber Calibre Caliber	Pos. Pos. Pos.	Einheit Unité Unit	Messwerte Valeurs mesurées Measured values	Kontrolle Contrôle Check	Bemerkungen Remarques Remarks
512, 513, 515	1	V	1,55	Batterie-Spannung Tension de la pile Battery voltage	Batterie herausnehmen und messen Enlever et mesurer la pile Remove battery for measuring
512, 513, 515	2	µA	1,10–1,85 2,20–2,65	Stromaufnahme Consom. de courant Power consumption	Ohne Batterie, mit externer Speisung Sans pile, avec alimentation externe Without battery, with external power supply
512, 513, 515	2	V	≤ 1,30	Funktionskontrolle bei Minimalspannung Contrôle de fonctionnement à tension minimale Check with lowest possible voltage	Ohne Batterie, mit externer Speisung Sans pile, avec alimentation externe Without battery, with external power supply
512, 513, 515	3	KΩ	1,90–2,10 2,35–2,55	Spulenwiderstand Résistance de la bobine Resistance of the coil	Ohne Batterie Sans pile Without battery
512, 513, 515	4	KΩ	∞	Spulenisolation Isolation de la bobine Coil insulation	Ohne Batterie Sans pile Without battery
512, 513, 515		Sek./Monat sec./mois sec./month	- 10/+ 20	Induktivsonde 60 Sek. Senseur inductif 60 sec. Inductive sensor 60 sec.	Mit Batterie Avec pile With battery

Einschalen / Werkzeuge

Emboîtage / outils

Casing / tools

Nr. H 51x.1A



Nr. H 51x.1T



SWISS MADE & SWISS PARTS	
Schraube Vis Screw	

Zeigersetzen

Maximale Aufpresskraft:

- Stunden und Minutenzeiger: max. 40N
- Sekundenzeiger: max. 30N

Beim Zeigersetzen muss das Werk abgestützt werden.

Poser les aiguilles

Force de chassage maximale:

- Aiguilles des heure et des minutes: max. 40N
- Aiguille des secondes: max. 30N

Lors de la pose d'aiguilles, le mouvement doit être soutenu.

Hand setting

Maximal force:

- Hour and minute hands: max. 40N
- Second hand: max. 30N

The movement needs to be supported for hand setting.

Kal. 512, 513 Stellwelle entfernen	Kal. 515 Stellwelle entfernen
Beim Entfernen der Stellwelle muss sich die Stellwelle in Position 1 (gedrückt) befinden, bevor auf den Winkelhebel gedrückt wird.	Beim Entfernen der Stellwelle muss sich die Stellwelle in Position 2 befinden, bevor auf den Winkelhebel gedrückt wird.
Kal. 512, 513 Enlever la tige	Kal. 515 Enlever la tige
En enlevant la tige, la tige doit se trouver en position 1 (poussée), avant de pousser sur la tirette.	En enlevant la tige, la tige doit se trouver en position 2 , avant de pousser sur la tirette.
Kal. 512, 513 Stem removal	Kal. 515 Stem removal
For removal of the stem, the stem must be in position 1 (pressed in) prior to apply pressure to the setting lever.	For removal of the stem, the stem must be in position 2 prior to apply pressure to the setting lever.